

1. FRAME & MISCELLANEOUS COVER COMPONENTS (1)

頭部・外装関係 (1)

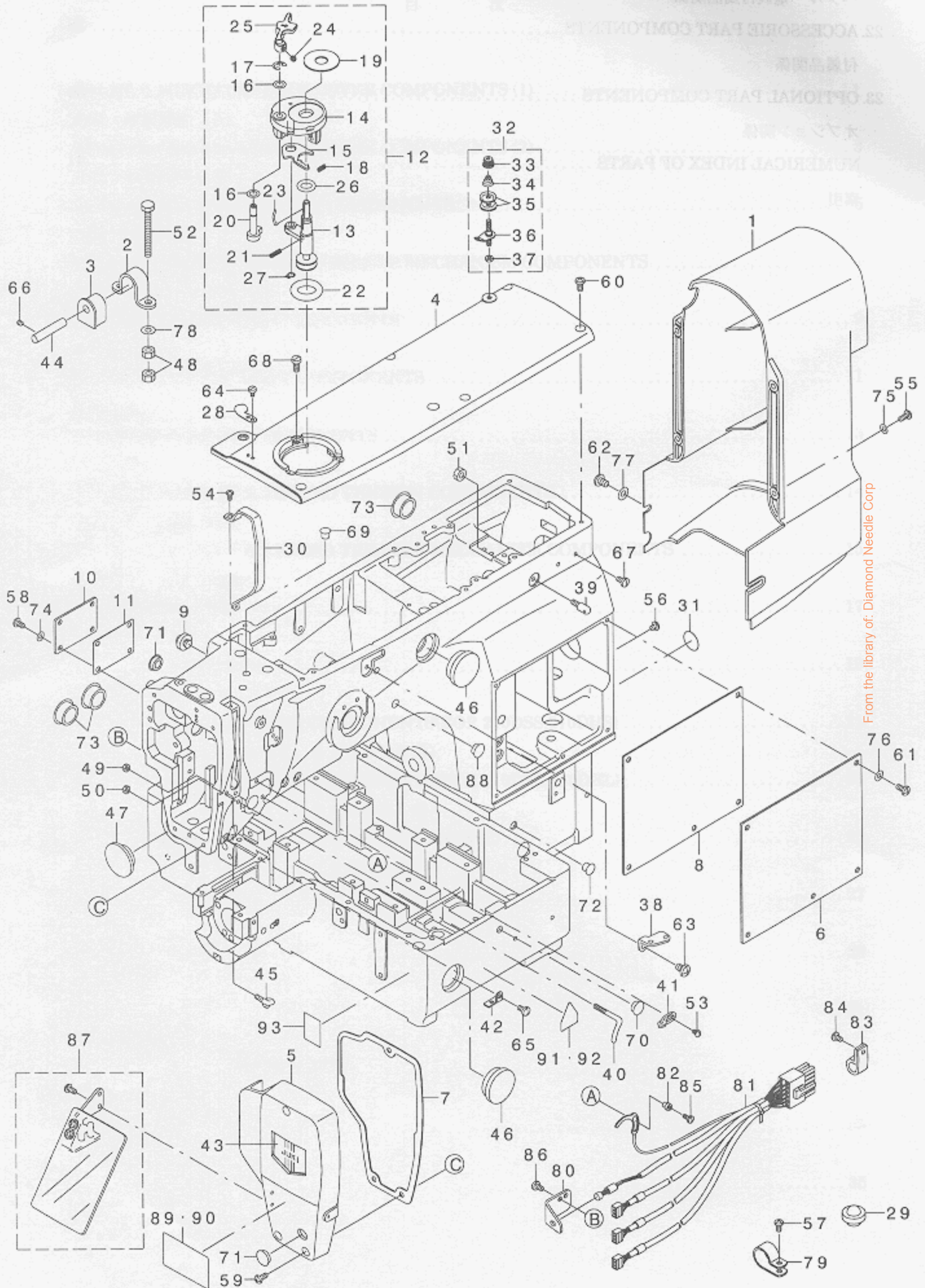

REF. NO	NOTE	PART NO.	DESCRIPTION	キ ャ ン 名 義	Qty
1		B1107-210-000	MOTOR COVER	モーターカバー	1
2		B1111-210-000	BED HINGE	ベッドヒンジ	2
3		B1115-210-000	HINGE RUBBER	ヒンジゴム	2
4		B1104-210-000	TOP COVER	トップカバー	1
5		B1105-210-000	FACE PLATE	メンブール	1
6		B1121-210-000	SIDE COVER	サイドカバー	1
7		B1117-210-000	FACE PLATE GASKET	メンブールパッキン	1
8		B1122-210-000	SIDE PLATE GASKET	サイドプレートパッキン	1
9		B1116-210-000	FRAME SUPPORT RUBBER	トウワチサシゴム	1
10		B1123-210-000	COVER	カバー	1
11		B1125-210-000	COVER GASKET	カバーパッキン	1
12		B3204-210-DB0	BOBBIN WINDER ASM.	イトマキウチ(クミ)	1
13		B3204-210-DA0	BOBBIN WINDER SHAFT COMPL.	イトマキシャフト(クミ)	(1)
14		225-37658	BOBBIN FITTING BASIS COMPL.	イトマキリサシゴイ(クミ)	(1)
15		225-38409	ADJUSTING PLATE	イトマキ調整板	(1)
16		106-18304	VERTICAL ROLLER WASHER	シャフトローラワッシャー	(2)
17		RE-0500000-K0	E-RING	Eリング	(1)
18		B1529-890-00C-A	PRESSUR FOOT SPRING	オシエネ	(1)
19		B3205-210-000	CUSHION	クッション	(1)
20		225-38151	BOBBIN CAM SHAFT COMPL.	イトマキカムシャフト(クミ)	(1)
21		B1148-555-000	SPRING	コイルスプリング	(1)
22		A3216-001-00A	RUBBER RING	ゴムリング	(1)
23		B3212-761-000	LATCH SPRING	クックスプリング	(1)
24		SS-8110422-TP	SCREW 11/64-40 L=4	ボルト 11/64-40 L=4	(1)
25		225-38300	BOBBIN LEVER	イトマキレバー	(1)
26		RO-D922702-00	RUBBER RING	リング	(1)
27		RC-0560711-KP	RETAINING RING	止りリング	(1)
28		105-02300	THREAD CUTTER	イトマキ切ネジ	1
29		110-47107	RUBBER CUSHION	トウワチサシゴム	3
30		138-16608	BALANCE COVER	テンションカバー	1
31		100-04109	GROUND MARK	グラウンドマーク	1
32		225-29465	BOBBIN THREAD TENSION ASM.	イトマキイトマキ調整(クミ)	1
33		110-72402	THREAD TENSION NUT	ダイ 1 イトマキ調整ナット	(1)
34		110-93606	THREAD TENSION SPRING	ダイ イトマキ調整スプリング	(1)
35		B3214-047-000	BOBBIN WINDER TENSION DISC	イトマキ調整ディスク	(2)
36		225-29457	THREAD TENSION ROD COMPL.	イトマキイトマキ調整シャフト(クミ)	(1)
37		NS-6110310-SP	NUT 11/64-40	ワッシャー 11/64-40	(1)
38		B1111-232-000	THREAD GUIDE PLATE	イトマキガイド	1
39		B1123-280-000	FIRST THREAD GUIDE	ダイ イトマキガイド	1
40		B1125-215-P00	L-SHAPED THREAD GUIDE	L型イトマキガイド	1
41		B1126-552-000	ARM THREAD GUIDE A	A型イトマキガイド	1
42		B1129-210-000	FRAME THREAD GUIDE (B)	B型イトマキガイド	1
43		B1178-191-000	FACE PLATE DRESSING TABLE	メンブール整頓台	1
44		B2707-761-000	HINGE STUD	ヒンジピン	2
45		B3114-771-000	THREAD GUIDE	イトマキガイド	1
46		B3501-210-000	OIL GAUGE	オイルゲージ	2
47		B8267-180-000	RUBBER PLUG	テーパープラグ	1
48		NM-6060001-SC	NUT M6	ワッシャー M6 13x	8
49		NS-6090310-SP	NUT 9/64-40	ワッシャー 9/64-40	1
50		NS-6090310-SP	NUT 9/64-40	ワッシャー 9/64-40	1
51		NS-6150310-SP	NUT 15/64-28	ワッシャー 15/64-28	1
52		SM-9065513-SF	SCREW M6X55	ワッシャー M6 L=55	4
53		SS-3090610-SP	SCREW 9/64-40 L=6	ボルト 9/64-40 L=6	1
54		SS-4090715-SP	SCREW 9/64-40 L=7	ボルト 9/64-40 L=7	2
55		SS-411015-SP	SCREW 11/64-40 L=10	ボルト 11/64-40 L=10	5
56		SS-4110515-SP	SCREW 11/64-40 L=5	ボルト 11/64-40 L=5	1
57		SS-4110915-SP	SCREW 11/64-40 L=9	ボルト 11/64-40 L=9	1
58		SS-4110815-SP	SCREW 11/64-40 L=8	ボルト 11/64-40 L=8	3
59		SS-4111015-SP	SCREW 11/64-40 L=10	ボルト 11/64-40 L=10	3
60		SS-4121015-SP	SCREW 3/16-28 L=10	ボルト 3/16-28 L=10	6
61		SS-4121015-SP	SCREW 3/16-28 L=10	ボルト 3/16-28 L=10	5
62		SS-4150915-SP	SCREW 15/64-28 L=9	ボルト 15/64-28 L=9	1
63		SS-4150915-SP	SCREW 15/64-28 L=9	ボルト 15/64-28 L=9	1
64		SS-6090620-SP	SCREW 9/64-40 L=6	ボルト 9/64-40 L=6	1
65		SS-7110840-SP	SCREW 11/64-40 L=7.8	ボルト 11/64-40 L=7.8	1
66		SS-8110422-TP	SCREW 11/64-40 L=4	ボルト 11/64-40 L=4	2
67		SS-7110840-SP	SCREW 11/64-40 L=7.8	ボルト 11/64-40 L=7.8	2
68		SS-6111140-SP	SCREW 11/64-40 L=11	ボルト 11/64-40 L=11	3
69		TA-0750704-RO	RUBBER PLUG	ボルト	1
70		TA-1050504-RO	RUBBER PLUG	ボルト	2
71		TA-1250406-RO	RUBBER PLUG D=12.5 L=4	ボルト D=12.5 L=4	2
72		TA-1680605-RO	PLUG	ボルト	1
73		TA-2100904-RO	RUBBER PLUG	ボルト	3
74		WP-0450000-SD	WASHER 4.5X8X0.5	ワッシャー 4.5X8X0.5	3
75		WP-0450000-SD	WASHER 4.5X8X0.5	ワッシャー 4.5X8X0.5	5
76		WP-0501016-SD	WASHER 5X10.5X1	ワッシャー 5X10.5X1	5
77		WP-0621016-SD	WASHER 6.2X13X1	ワッシャー 6.2X13X1	1
78		WP-0621016-SD	WASHER 6.2X13X1	ワッシャー 6.2X13X1	4
79		HX-0015000-OJ	CLIP	クリップ	1
80		B4110-210-000	STOP-SWITCH INSTALLING PLATE	イオンスイッチ取り付け板	1
81		B4130-210-DA0	SENSOR CABLE ASM.	トウワチケーブル	1
82		B2703-210-000	BUSHING	イトマキケーブルアダプター	1
83		HX-0012300-OA	CABLE CLIP	ケーブルクリップ	3
84		SS-4110715-SP	SCREW 11/64-40 L=7	ボルト 11/64-40 L=7	3
85		SS-7090850-SP	SCREW 9/64-40 L=8	ボルト 9/64-40 L=8	1
86		SS-7110710-SP	SCREW 11/64-40 L=7	ボルト 11/64-40 L=7	2
87		135-51254	SAFETY PLATE ASM.	アンププレート(クミ)	1
88	#01	TA-1050504-RO	RUBBER PLUG	ボルト	2
89	#02	CM-3002003-01	SAFETY LABEL, 5(SMALL).	アンプラベル 5(小)	1
90	#03	CM-3002003-A1	SAFETY LABEL, 6 (SMALL).	アンプラベル 6(小)	1
91	#02	CM-3002000-B2	LABEL(25).	アンプラベル 25	1
92	#04	CM-3002000-02	CAUTION LABEL(25)	注意ラベル 25	1
93	#04	B1143-210-000	LABEL	注意ラベル	1

NOTE (注記)

#01... FOR 210DSL, DHL
 #02... FOR DOMESTIC USE
 #03... FOR EXPORT
 #04... FOR JE

210DSL, DHL用
 国内用
 輸出用
 JE用

From the library of: Diamond Needle Corp

2. FRAME & MISCELLANEOUS COVER COMPONENTS (2)

頭部・外装関係 (2)

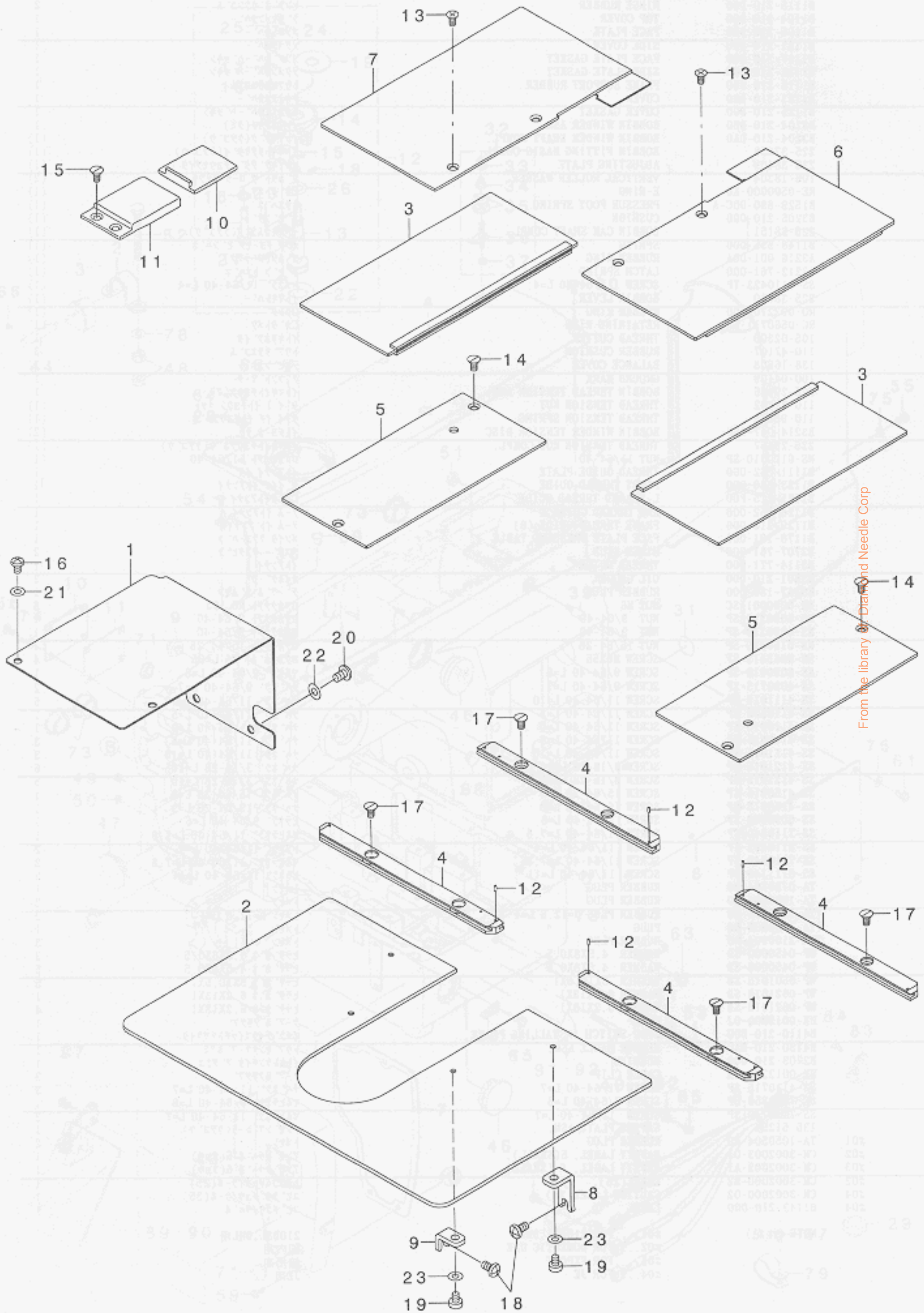

REF. NO	NOTE	PART NO.	DESCRIPTION	品名	Qty
1		B1106-210-D00	X MOTOR COVER	Xモータカバー	1
2		B1112-210-D00	NEEDLE PLATE SUPPORT COVER	ハリイタホシヨカハ	1
3		B1109-210-DA0	X MOVEMENT LOWER COVER ASM.	Xイトウシタカハクミ	2
4		B1181-210-D00	X MOVEMENT COVER RAIL	Xイトウカハレール	4
5		B1108-210-D00	FEED BASE COVER	オクリタイカハ	2
6		B1110-210-DA0	X MOVEMENT UPPER COVER ASM., R	Xイトウウエカハミキクミ	1
7		B1118-210-DA0	X MOVEMENT UPPER COVER ASM., L	Xイトウウエカハヒタリクミ	1
8		B1113-210-D00	COVER SUPPORT	ハリイタホシヨカハササエ	2
9		B1113-223-C00	COVER SUPPORTER	ハリイタホシヨカハササエ	2
10		B1123-210-000	Y DRIVE COVER	Yイトウカハ	1
11		B1124-210-000	Y FIXED COVER	Yコテイカハ	1
12		PS-0150042-K0	SPRING PIN 1.5X 4	スプリングピン 1.5X 4	4
13		SM-1040801-SC	SCREW M4X0.7 L=8	サライネジ M4X0.7 L=8	4
14		SS-1110840-SP	SCREW 11/64-40 L=8	サライネジ 11/64-40 L=8	4
15		SS-1110840-SP	SCREW 11/64-40 L=8	サライネジ 11/64-40 L=8	2
16		SS-4110715-SP	SCREW 11/64-40 L=7	ナネジ 11/64-40 L=7	2
17		SS-1110840-SP	SCREW 11/64-40 L=8	サライネジ 11/64-40 L=8	8
18		SS-4120915-SP	SCREW 3/16-28 L=9	ナネジ 3/16-28 L=9	4
19		SS-6110610-TP	SCREW 11/64-40 L=6	ヒライネジ 11/64-40 L=6	4
20		SM-4050855-SP	SCREW	ナネジ M5 L=8	2
21		WP-0450801-SD	WASHER 4.5X10X0.8	ヒライサカネ 4.5X10X0.8	2
22		WP-0531000-SD	WASHER M5	ヒライサカネ コカタマル M5	2
23		WP-0520656-SA	WASHER 5.2X9.5X0.6	ヒライサカネ 5.2X9.5X0.6	4

From the library of: Diamond Needle Corp

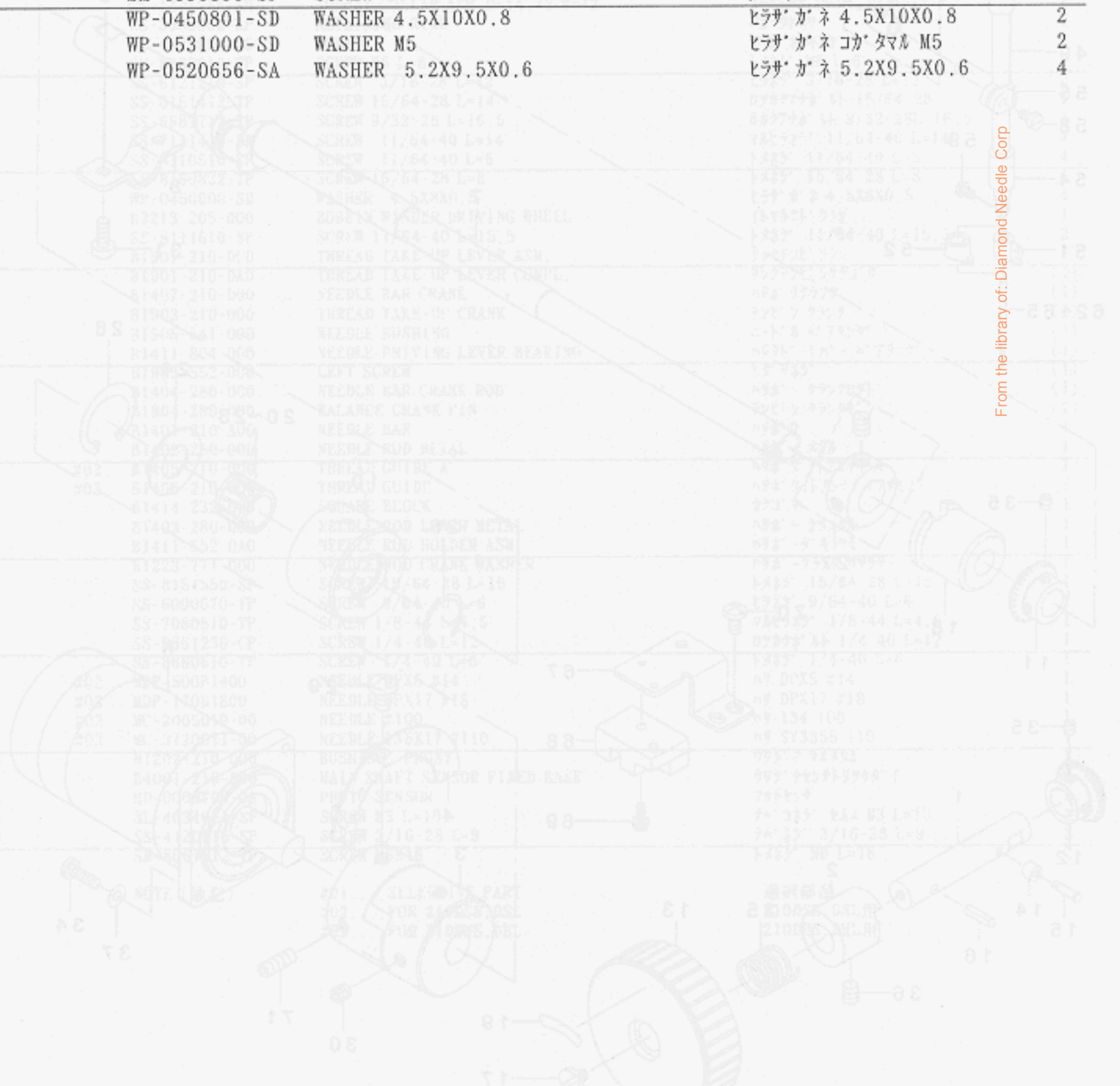

3. MAIN SHAFT & NEEDLE BAR COMPONENTS

上軸・針棒関係

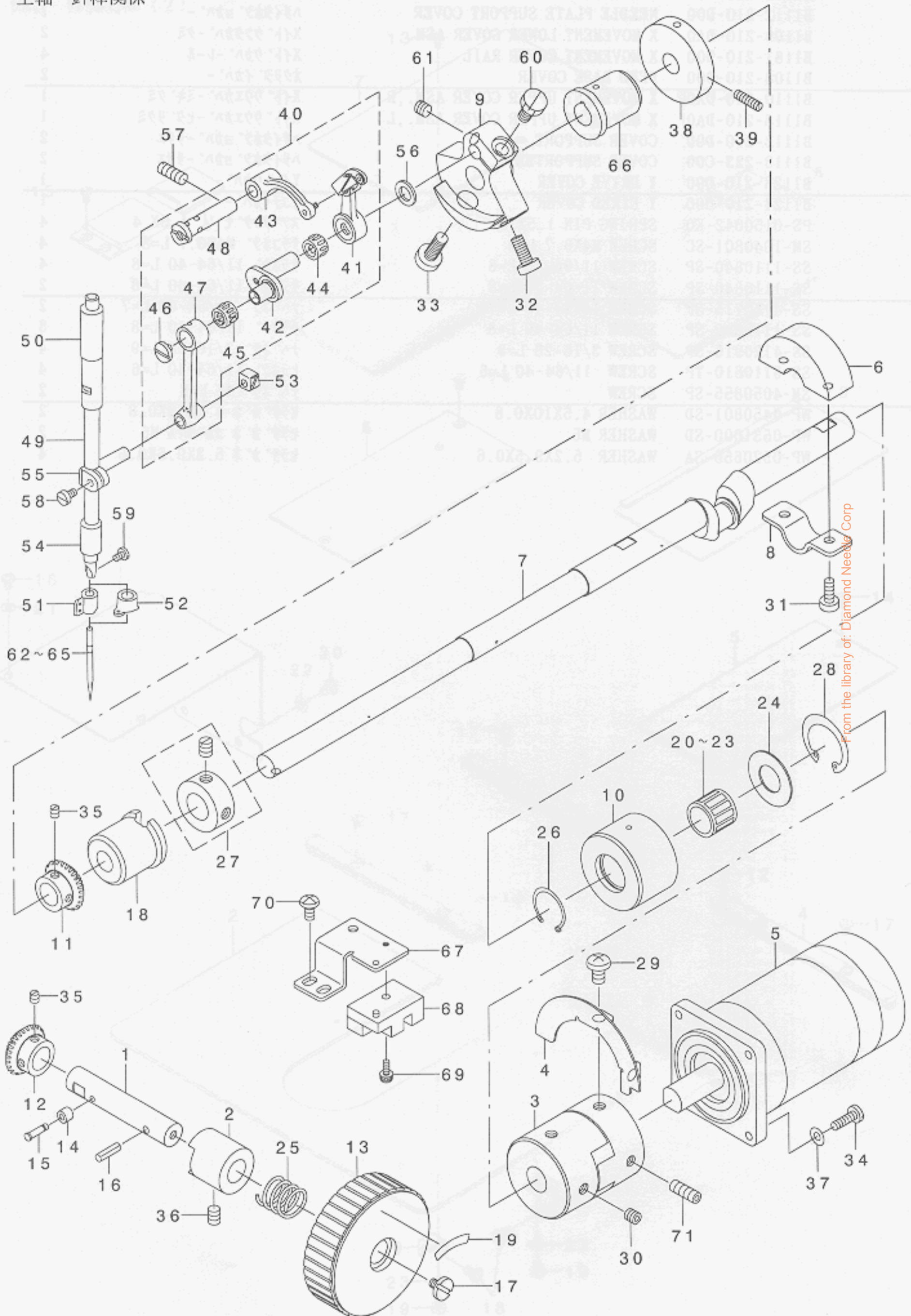

From the library of: Diamond Needle Corp

REF. NO	NOTE	PART NO.	DESCRIPTION	品名	Qty
1		B1213-210-D00	PULLEY SHAFT	デモトア-リシク	1
2		B1214-210-D00	PULLEY BUSHING	デモトア-リシク	1
3		B1231-210-D00	COUPLING	カップ リンク	1
4		B1232-210-D00	MAIN SHAFT SLIT PLATE	ウツシ クスリットイタ	1
5		B1230-210-D00	MAIN MOTOR	シュモータ	1
6		B1207-210-D00	CRANK BALANCER	クランクバランサ	1
7		B1201-210-D00	MAIN SHAFT	ウツシク	1
8		B1208-210-D00	CRANK BALANCER FIX PLATE	クランクバランサ-コテイイタ	1
9		B1206-210-D00	COUNTERWEIGHT	ツリアイスイ	1
10		B1203-210-D00	MAIN SHAFT REAR BUSHING	ウツシク ウツシロメタル	1
11		B1215-210-D00	PULLEY GEAR, A	デモトア-リシク ルマA	1
12		B1216-210-D00	PULLEY GEAR, B	デモトア-リシク ルマB	1
13		B1212-210-D00	PULLEY	デモトア-リ	1
14		112-17213	ROLLER	シヨウケホウコ	1
15		112-17114	ROLLER SHAFT	シヨウケホウコ	1
16		PS-0400142-KH	SPRING PIN 4X14	スプリングピン 4X14	1
17		A1230-500-000-A	HANDWHEEL SETSCREW	ハズミクルマトメネジ	1
18		B1203-210-000	BUSHING, INTERMEDIATE	ウツシク ナカメタル	1
19		B1144-210-000	REVOLVING DIRECTION LABEL	カイトンホウコウラハ	1
20	#01	B1208-980-00A	MAIN SHAFT NEEDLE BEARING A	ウツシク ニートルハアリング A	1
21	#01	B1208-980-00B	MAIN SHAFT NEEDLE BEARING B	ウツシク ニートルハアリング B	1
22	#01	B1208-980-00C	MAIN SHAFT NEEDLE BEARING C	ウツシク ニートルハアリング C	1
23	#01	B1208-980-00D	MAIN SHAFT NEEDLE BEARING D	ウツシク ニートルハアリング D	1
24		B1643-470-000	THRUST WASHER	オクリレハ-シクキト-ワ	1
25		GAF-01007000	SPRING	オクリコテイハネ	1
26		D1232-555-B00	SNAP RING	ニートルトメワ	1
27		CS-147121E-SH	THRUST COLLAR ASM. D=14.72 W=12	スラストウケ D=14.72 W=12 クミ	1
28		RC-3000002-KP	RETAINING RING	Cカトメワ	1
29		SL-4061091-SC	SCREW	チカネツキネジ	2
30		SM-8060612-TP	SCREW M6 L=6	トメネジ M6 L=6	2
31		SS-6121210-SP	SCREW 3/16-28 L=12	ヒラネジ 3/16-28 L=12	2
32		SS-6151412-TP	SCREW 15/64-28 L=14	ロツカクナホ ルト 15/64-28	1
33		SS-6681712-TP	SCREW 9/32-28 L=16.5	6カクナホ ルト 9/32-28 L=16.5	1
34		SS-7111410-SP	SCREW 11/64-40 L=14	マルヒラネジ 11/64-40 L=14	4
35		SS-8110510-SP	SCREW 11/64-40 L=5	トメネジ 11/64-40 L=5	4
36		SS-8150822-TP	SCREW 15/64-28 L=8	トメネジ 15/64-28 L=8	1
37		WP-0450000-SD	WASHER 4.5X8X0.5	ヒラサカネ 4.5X8X0.5	4
38		B3213-205-000	BOBBIN WINDER DRIVING WHEEL	イトマキクウツシ	1
39		SS-8111610-SP	SCREW 11/64-40 L=15.5	トメネジ 11/64-40 L=15.5	2
40		B1901-210-DC0	THREAD TAKE-UP LEVER ASM.	リンクデンビソクミ	1
41		B1901-210-DA0	THREAD TAKE-UP LEVER COMPL.	リンクデンビソクミ	(1)
42		B1407-210-D00	NEEDLE BAR CRANK	ハリホウクランク	(1)
43		B1903-210-000	THREAD TAKE-UP CRANK	デンビソクランク	(1)
44		B1905-541-000	NEEDLE BUSHING	ニートルハアリング	(1)
45		B1411-804-000	NEEDLE DRIVING LEVER BEARING	ハリホウレハ-ハアリング	(1)
46		B1903-552-000	LEFT SCREW	ヒラネジ	(1)
47		B1404-280-000	NEEDLE BAR CRANK ROD	ハリホウクランクログト	(1)
48		B1904-280-000	BALANCE CRANK PIN	デンビソクランクピン	(1)
49		B1401-210-A00	NEEDLE BAR	ハリホウ	1
50		B1402-280-000	NEEDLE ROD METAL	ハリホウメタル	1
51	#02	B1405-210-000	THREAD GUIDE A	ハリホウイトアンナイA	1
52	#03	B1406-210-000	THREAD GUIDE	ハリホウイトアンナイ(アツモノ)	1
53		B1414-232-000	SQUARE BLOCK	カクコマ	1
54		B1403-280-000	NEEDLE ROD LOWER METAL	ハリホウシタメタル	1
55		B1411-552-0A0	NEEDLE ROD HOLDER ASM.	ハリホウタキクミ	1
56		B1223-771-000	NEEDLE ROD CRANK WASHER	ハリホウクランクワツシ	1
57		SS-8151550-SP	SCREW 15/64-28 L=15	トメネジ 15/64-28 L=15	1
58		SS-6090670-TP	SCREW 9/64-40 L=6	ヒラネジ 9/64-40 L=6	1
59		SS-7080510-TP	SCREW 1/8-44 L=4.5	マルヒラネジ 1/8-44 L=4.5	1
60		SS-9661230-CP	SCREW 1/4-40 L=12	ロツカクナホ ルト 1/4-40 L=12	1
61		SS-8660610-TP	SCREW 1/4-40 L=6	トメネジ 1/4-40 L=6	1
62	#02	MDP-500B1400	NEEDLE DPX5 #14	ハリDPX5 #14	1
63	#03	MDP-170B1800	NEEDLE DPX17 #18	ハリDPX17 #18	1
64	#02	MC-2005010-00	NEEDLE #100	ハリ134 100	1
65	#03	MC-3720011-00	NEEDLE 135X17 #110	ハリSY3355 110	1
66		B1202-210-000	BUSHING, FRONT	ウツシクマメタル	1
67		B4001-210-D00	MAIN SHAFT SENSOR FIXED BASE	ウツシクセンサトリツクタイ	1
68		HD-0005700-0A	PHOTO SENSOR	フォトセンサ	1
69		SL-4031081-SP	SCREW M3 L=10	チハコネジ 7.5X M3 L=10	1
70		SS-4120915-SP	SCREW 3/16-28 L=9	チハネジ 3/16-28 L=9	2
71		SM-8061612-TP	SCREW M6X16	トメネジ M6 L=16	2

NOTE (注記)

NOTE (注記)

#01...SELECTIVE PART
 #02...FOR 210DSS,DSL
 #03...FOR 210DHS,DHL

選択部品
 210DSS,DSL用
 210DHS,DHL用

From the library of: Diamond Needle Corp

4. PRESSER PLATE & MANUAL PRESSER MECHANISM COMPONENTS

押え・マニュアル押え関係

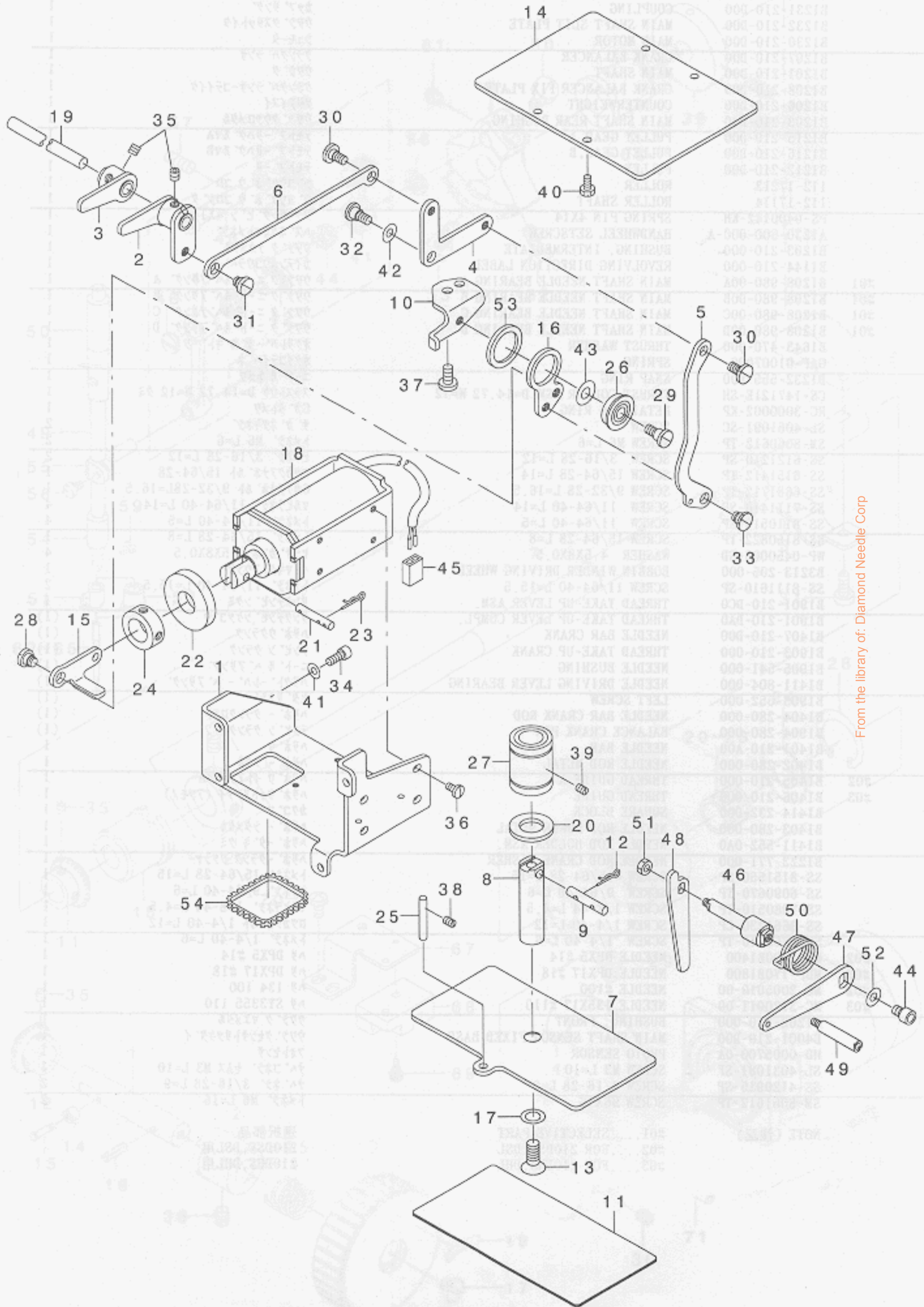

From the library of: Diamond Needle Corp

REF. NO	NOTE	PART NO.	DESCRIPTION	品名	Qty
1		B1507-210-D00	MAGNET INSTALLING PLATE	マグ ネットトリツケイタ	1
2	#01	B1501-210-DA0	ARM ASM., A	オシサケ ウデ Aクミ	1
3	#01	B1503-210-DA0	ARM ASM., B	オシサケ ウデ Bクミ	1
4	#01	B1504-210-D00	L-SHAPED LINK	オサエLカ タリンク	1
5	#01	B1505-210-D00	CONNECTING PLATE	オサエレンクツイタ	1
6	#01	B1506-210-D00	CONNECTING LINK	オサエレンクツリンク	1
7	#01	B1502-210-D00	PRESSER PLATE	オサエイタ	1
8	#01	B1525-210-D00	PRESSER SHAFT	オサエシク	1
9	#01	B1508-210-D00	PIN	オシサケ ピン	1
10	#01	B1509-210-D00	LINK GUIDE PLATE	リンクカ イト イタ	1
11		B1520-210-D00	PRESSER PLATE SHEET	オサエイタシート	1
12	#01	B1515-210-D00	PIN	マツハ ピン	2
13	#01	B1516-210-D00	SCREW	オサエイタケツゴ ウネシ	1
14	#02	B1522-210-D00	PRESSER PLATE(PNEUMATIC TYPE)	オサエイタAIRシヨウ	1
15	#01	B1510-210-D00	MAGNET LINK	マグ ネットリンク	1
16	#01	B1511-210-D00	PRESSER LINK	オサエトク ルリンク	1
17	#01	B1530-210-D00	PRESSER PLATE SHEET WASHER	オサエイタシートサ カネ	3
18	#01	B1628-210-D00	PRESSER SOLENOID	オサエソレノイト	1
19	#01	B1701-210-000	LOWERING SHAFT	オシサケ シテンシク	1
20	#01	D3310-555-D00	RUBBER WASHER	イトタテホ - ホ - シンゴ ム	1
21	#01	B1513-210-D00	MAGNET PIN	マグ ネットピン	1
22	#01	D2468-555-B00	RUBBER PLUNGER	プ ランジ ヤー ゴ ム	1
23	#01	B1515-210-D00	PIN	マツハ ピン	2
24	#01	CS-1701011-SZ	THRUST COLLAR D=17 W=10	スラストウケ D=17 W=10	1
25	#01	PH-0500322-C0	PIN 5X32	ハイコ ピン 5X32	1
26	#01	SB-1080005-00	RADIAL BEARING	ラジ アルジ クウク	1
27	#01	SB-7160002-00	BEARING	コロカ リジ クウク	1
28	#01	SD-0800341-SP	HINGE SCREW D=8 H=3.4	タ' ヲネシ' D=8 H=3.4	1
29	#01	SD-0790601-SP	HINGE SCREW D=7.94 H=6	タ' ヲネシ' D=7.94 H=6	1
30	#01	SD-0720331-SP	HINGE SCREW D= 7.24 H= 3.3	タ' ヲネシ' D=7.24 H=3.3	2
31	#01	SD-0800341-SP	HINGE SCREW D=8 H=3.4	タ' ヲネシ' D=8 H=3.4	1
32	#01	SD-0790501-SP	HINGE SCREW D=7.94 H=5	タ' ヲネシ' D=7.94 H=5	1
33	#01	SD-0800422-CP	HINGE SCREW D= 8 H= 4.2	タ' ヲネシ' D=8 H=4.2	1
34		SM-6051202-TP	SCREW M5X0.8 L=12	ロツカクアナホ' ルト M5X0.8 L=12	4
35	#01	SM-8060612-TP	SCREW M6 L=6	トメネシ' M6 L=6	4
36	#01	SS-7110840-SP	SCREW 11/64-40 L=7.8	マルヒラネシ' 11/64-40 L=7.8	4
37	#01	SS-7151210-SP	SCREW 15/64-28 L=12	マルヒラネシ' 15/64-28 L=12	2
38	#01	SS-8120740-SP	SCREW 3/16-28 L=7	トメネシ' 3/16-28 L=7	1
39	#01	SS-8120740-SP	SCREW 3/16-28 L=7	トメネシ' 3/16-28 L=7	1
40	#02	SS-9120910-TP	SCREW 3/16-28 L=9	ロツカクホ' ルト 3/16-28 L=9	4
41		WP-0531001-SC	WASHER	ヒラサ' カネ ミカ' キマル M5	4
42	#01	WP-0850002-SP	WASHER 8.5X18X1.6	ヒラサ' カネ 8.5X18X1.6	1
43	#01	WP-0621016-SH	WASHER	ヒラサ' カネ	1
44		SM-6060802-TP	SCREW M6 L=8	ロツカクアナホ' ルト M6 L=8	1
45	#01	HK-0346100-2D	HOUSING	ハウジ' シク	1
46		B1701-210-D00	LOWERING LEVER SHAFT	オシサケ レハ' -シ' ク	1
47		B1702-210-D00	LOWERING LEVER	オシサケ レハ' -	1
48		B1703-210-D00	LOWERING PLATE	オシサケ イタ	1
49		113-92107	OIL PUMP SUPPORT	ホ' シ' ア' タイ シチユウ	1
50		B1526-804-000	SPRING	オサエアケ' レハ' - ハ' ネ	1
51		NM-6050001-SD	NUT M5X0.8	ロツカクナツト M5X0.8 1ツ	1
52		WP-0641601-SC	WASHER	ヒラサ' カネ ミカ' キマル M6	1
53	#01	WP-2232916-SZ	WASHER	ヒラサ' カネ 22.3X30X2.9	1
54		HX-0022300-0A	BUSHING	ブ' ヲシユ	1
		NOTE (注記)	#01...FOR 210DSS, DHS	210DSS, DHS用	
			#02...FOR 210DSL, DHL	210DSL, DHL用	

5. PRESSER MECHANISM COMPONENTS

中押さえ関係

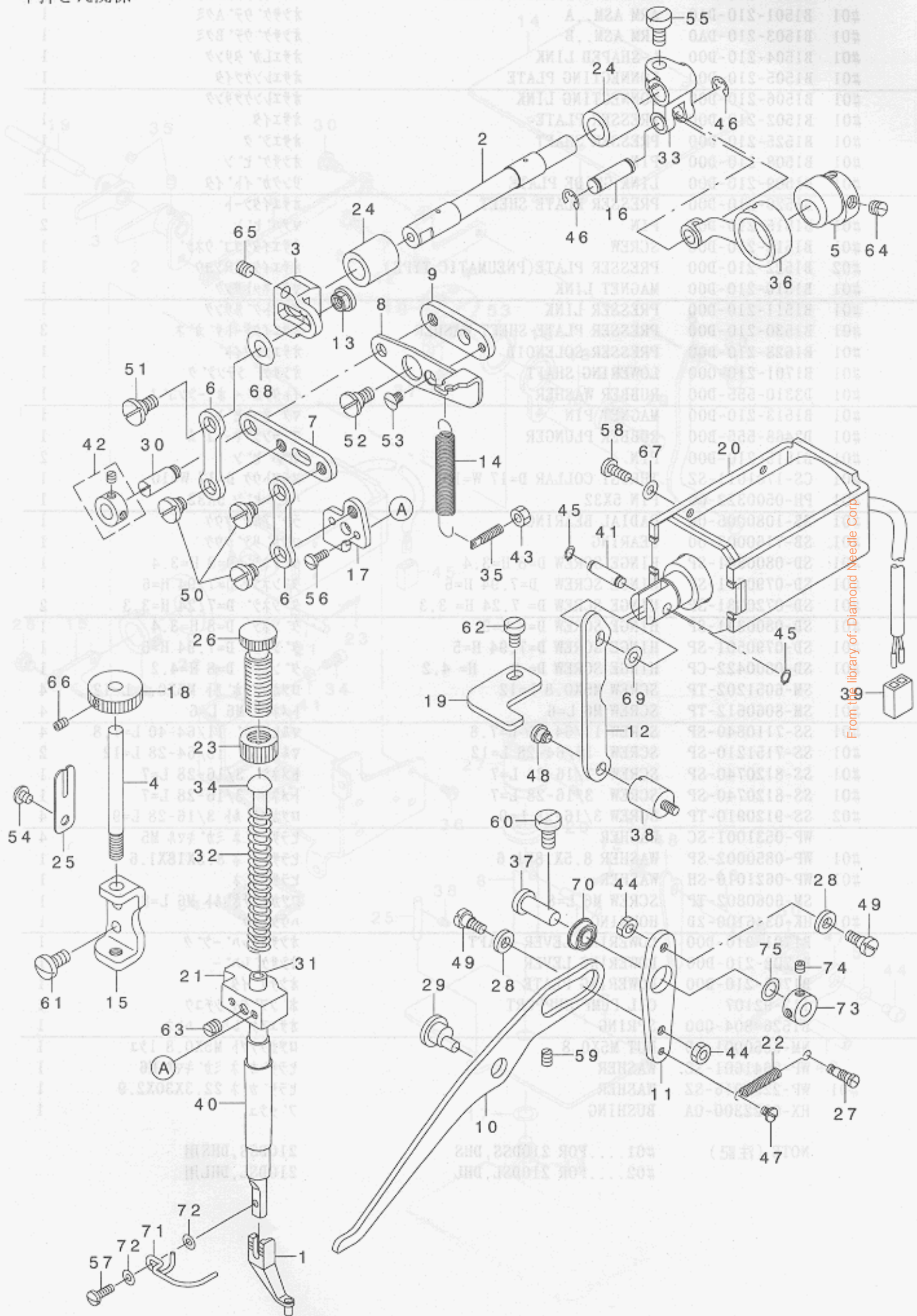

From the library of: Diamond Needle Corp

REF. NO	NOTE	PART NO.	DESCRIPTION	キ ャ ム イ	Qty
1		B1601-210-D00	INTERMEDIATE PRESSER, A	ナカオサエA	1
2		B1604-210-D00	INTERMEDIATE PRESSER SHAFT	ナカオサエヨウトウウツク	1
3		B1603-210-D00	ADJUSTING ARM	ナカオサエチヨウセツウデ	1
4		B1630-210-D00	ADJUSTING SHAFT	ナカオサエチヨウセツウツク	1
5		B1609-210-D00	ECCENTRIC CAM	ナカオサエヘンジンカム	1
6		B1612-210-D00	INTERMEDIATE PRESSER LINK, A	ナカオサエリンクA	2
7		B1610-210-D00	INTERMEDIATE PRESSER LINK, B	ナカオサエリンクB	1
8		B1606-210-D00	POSITIONING LINK A	ナカオサエイチキメリンクA	1
9		B1607-210-D00	POSITIONING LINK B	ナカオサエイチキメリンクB	1
10		B1620-210-D00	LIFTING LINK A	ナカオサエアゲリンクA	1
11		B1621-210-D00	LIFTING LINK B	ナカオサエアゲリンクB	1
12		B1622-210-D00	LIFTING LINK C	ナカオサエアゲリンクC	1
13		B1633-210-D00	ADJUSTING NUT	ナカオサエチヨウセツナット	1
14		B1642-210-D00	INTERMEDIATE PRESSER SPRING B	ナカオサエハネB	1
15		B1632-210-D00	ADJUSTING SHAFT BRACKET	ナカオサエチヨウセツウツクラケット	1
16		B1627-210-D00	ROD CONNECTING SHAFT	ナカオサエロッドリンクウツク	1
17		B1611-210-D00	LINK CONNECTING PLATE	ナカオサエリンクチェウケイタ	1
18		B1631-210-D00	HEIGHT ADJUSTING KNOB	ナカオサエタカサチヨウセツツマミ	1
19		B1629-210-D00	MAGNET STOPPER	ナカオサエマグネットストップ	1
20		B1628-210-D00	PRESSER SOLENOID	オサエソレノイド	1
21		110-06004	PRESSER BAR GUIDE BRACKET	オサエウダキ	1
22		110-10303	FEED REVERSE SPRING	オクリハネハネ	1
23		110-71701	NUT	オサエチヨウセツナット	1
24		118-47308	BUSHING, REAR	ウツメスジクウツロメタル	2
25		137-17707	ROCKING ADJUSTING SCREW STOPPE	ヨウトウチヨウセツナットストップ	1
26		110-71602	PRESSER SPRING REGULATOR	オサエチヨウセツナット	1
27		137-16907	SUSPENSION SCREW	キセンチヨウセツハネカケ	1
28		137-22509	DRIVING SAFETY ROLLER	キトウアンセソコ	2
29		B1641-562-000	FEED REGULATING ARM SHAFT	オクリチヨウセツウツク	1
30		B1408-180-000	HINGE SCREW	ハリハネジョウケリンクピン	1
31		B1501-127-000	PRESSER BAR	オサエウダ	1
32		B1611-210-00A	INNER PRESSER SPRING,	ナカオサエハネ	1
33		B1611-804-000-A	FORKED CRANK	オクリフタマタクランク	1
34		B1629-224-000	PRESSER GUIDE BAR	ナカオサエアンナイハネウ	1
35		B1649-161-000	TENSION SPRING ADJUSTING SCREW	ヒツハネハネチヨウセツナット	1
36		B2102-816-000-A	CHAIN LOOPER ROD (22MM)	ニジンユカンロッド	1
37		B1615-210-D00	LIFTING LINK B SHAFT	ナカオサエアゲリンクBシャフト	1
38		B8404-352-000	BELT COVER SUPPORT STUD	ベルトカバーササエネジ	1
39		HK-0346100-2E	CONNECTOR	コネクタ	1
40		D1510-491-D00	BUSHING, LOWER	オサエウツメタル	1
41		B1626-210-D00	PIN	ナカオサエアゲマグネットウツククビソ	1
42		CS-079073A-SH	THRUST COLLAR ASM.	スラストウケクミ	1
43		NS-6110310-SP	NUT 11/64-40	ロツカクナット 11/64-40	1
44		NS-6620310-SP	NUT 3/16-32	ロツカクナット 3/16-32	2
45		RC-0470611-KP	RETAINING RING 4.7	Cガタメツ 4.7	2
46		RE-0500000-KO	E-RING	Eガタメツ 5	2
47		SD-0400191-TP	HINGE SCREW D=4 H=1.8	ダッネジ D=4 H=1.8	1
48		SD-0640321-SP	HINGE SCREW D= 6.35 H= 3.2	ダッネジ D=6.35 H=3.2	1
49		SD-0600402-TP	HINGE SCREW D= 6 H= 4	ダッネジ D=6 H=4	2
50		SD-0800341-SP	HINGE SCREW D=8 H=3.4	ダッネジ D=8 H=3.4	3
51		SD-0800402-TP	HINGE SCREW D= 8 H= 4	ダッネジ D=8 H=4	1
52		SD-0790402-TP	HINGE SCREW D= 7.94 H= 4	ダッネジ D=7.94 H=4	1
53		SS-1110640-TP	SCREW 11/64-40 L= 5.5	チラネジ 11/64-40 L=5.5	1
54		SS-6110610-TP	SCREW 11/64-40 L=6	ヒラネジ 11/64-40 L=6	1
55		SS-6151220-SP	SCREW 15/64-28 L=11.5	ヒラネジ 15/64-28 L=11.5	1
56		SS-7090910-SP	SCREW 9/64-40 L= 8.5	マルヒラネジ 9/64-40 L=8.5	2
57		SS-7091110-SP	SCREW 9/64-40 L=10.5	マルヒラネジ 9/64-40 L=10.5	1
58		SS-7111120-SP	SCREW 11/64-40 L=10.5	マルヒラネジ 11/64-40 L=10.5	2
59		SS-8120740-SP	SCREW 3/16-28 L=7	トメネジ 3/16-28 L=7	1
60		SS-6151220-SP	SCREW 15/64-28 L=11.5	ヒラネジ 15/64-28 L=11.5	1
61		SS-7151210-SP	SCREW 15/64-28 L=12	マルヒラネジ 15/64-28 L=12	2
62		SS-6120940-SP	SCREW 3/16-28 L=9	ヒラネジ 3/16-28 L=9	1
63		SS-8660610-TP	SCREW 1/4-40 L=6	トメネジ 1/4-40 L=6	1
64		SS-8660610-TP	SCREW 1/4-40 L=6	トメネジ 1/4-40 L=6	2
65		SM-8060602-TP	SCREW M6X6	トメネジ M6 L=6	1
66		SM-8040602-TP	SCREW M4X0.7 L=6	トメネジ	1
67		WP-0450000-SD	WASHER 4.5X8X0.5	ヒラサカネ 4.5X8X0.5	2
68		WP-0611626-SP	WASHER 15X6X1.6	ヒラサカネ	1
69		WP-0611626-SP	WASHER 15X6X1.6	ヒラサカネ	1
70		SB-1070001-00	BEARING	コロカクツク	1
71		B1634-210-D00	FINGER GUARD	ユビガード	1
72		WP-0430800-SC	WASHER M4	ヒラサカネ コカタマル M4	2
73		CS-0700811-SH	THRUST COLLAR D=7 W=8	スラストウケ D=7 W=8	1
74		SS-8110422-TP	SCREW 11/64-40 L=4	トメネジ 11/64-40 L=4	2
75		WP-0740516-SP	WASHER 7.4X11.8X0.5	ヒラサカネ 7.4X11.8X0.5	1

From the library of: Diamond Needle Corp

6. SHUTTLE DRIVER SHAFT COMPONENTS

下軸関係

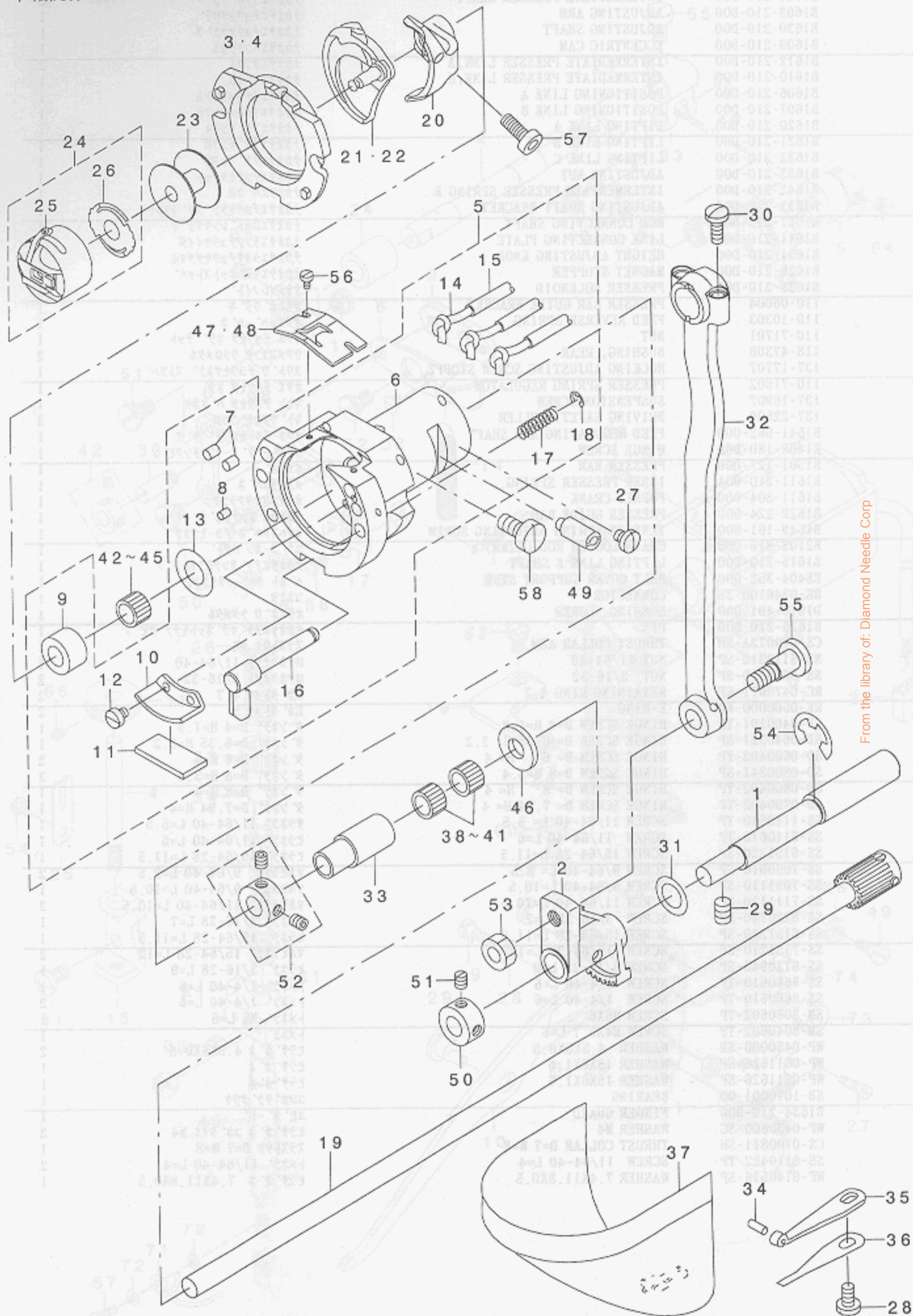

From the library of: Diamond Needle Corp

REF. NO	NOTE	PART NO.	DESCRIPTION	品名	Qty
1		B1836-210-D00	OSCILLATING ECCENTRIC SHAFT	オオフリコヘンサンジク	1
2		B1805-210-D00	OSCILLATOR	ウモジクオオフリコ	1
3	#01	B1817-210-DAA	SHUTTLE RACE RING COMPL., A	ナカガ マオチエAケツゴウ	1
4	#02	B1817-210-DAB	SHUTTLE RACE RING COMPL., B	ナカガ マオチエBケツゴウ	1
5		B1814-210-DAO	SHUTTLE ASM.	オオガ マグミ	1
6		B1814-210-D00	SHUTTLE	オオガ マ	(1)
7		B1820-210-D00	SHUTTLE OIL FELT, A	オオガ マキユウエアナフェルトA	(2)
8		B1821-210-D00	SHUTTLE OIL FELT, B	オオガ マキユウエアナフェルトB	(1)
9		B1813-980-000	SHUTTLE NEEDLE OUTER RING	オオガ マ ニート ルカ イリン	(1)
10		B3505-280-000	SHUTTLE LUBRICATING PLATE	オオガ マ キユ-ユイタ	(1)
11		B3504-280-000	SHUTTLE FELT	オオガ マフェルト	(1)
12		SS-6090440-SP	SCREW 9/64-40 L= 4.0	ヒラネジ 9/64-40 L=4	(2)
13		WP-0952616-SD	WASHER 9.5X14.8X2.6	ヒラサガネ 9.5X14.8X2.6	(1)
14		CQ-2522000-00	OIL WICK	ユラン	(1.3)
15		BP-3000000-00	VINYL PIPE	ビニールパイプ	(0.8)
16		B1820-215-PA0-A	INNER HOOK PRESSER ASM.	ナカガ マオチエアツクケツゴウ	(2)
17		B1822-215-P00	INNER HOOK PRESSER SPRING	ナカガ マオチエハネ	(2)
18		RE-0300000-KO	E-RING 3	Eカ タメワ 3	(2)
19		B1811-210-DAO	SHUTTLE DRIVER SHAFT ASM.	ウモジクハク ルマケツゴウ	1
20		B1812-210-D00	SHUTTLE DRIVER	トライハ	1
21	#01	B1818-210-DOA	SHUTTLE	ナカガ マ	1
22	#02	B1818-210-DOB	SHUTTLE, H	Hヨウナカガ マ	1
23		B1806-210-D00	BOBBIN	ホビソ	1
24		B1828-210-DAA	BOBBIN CASE ASM.	ホビソケースミ	1
25		B1828-210-DOA	BOBBIN CASE	ホビソケース	(1)
26		B1808-210-D00	SPRING	クウテンホウウツハネ	(1)
27		SS-7110510-SP	SCREW 11/64-40 L=5	マルヒラネジ 11/64-40 L=5	1
28		SS-7110840-SP	SCREW 11/64-40 L=7.8	マルヒラネジ 11/64-40 L=7.8	1
29		SS-8150822-TP	SCREW 15/64-28 L=8	トメネジ 15/64-28 L=8	2
30		SS-7111110-TP	SCREW 11/64-40 L=10.5	マルヒラネジ 11/64-40 L=10.5	2
31		105-23504	WASHER	カマジクサガネ	1
32		B1802-210-D00	CRANK ROD	クランクロッド	1
33		135-08403	LOWER SHAFT REAR METAL	シタジクウシロメタル	1
34		135-08700	HOOK COVER PRESSER SPRING PIN	カマカハ - オチエハネピン	1
35		135-08809	HOOK COVER PRESSER SPRING A	カマカハ - オチエハネ A	1
36		135-08908	HOOK COVER PRESSER SPRING B	カマカハ - オチエハネ B	1
37		138-16855	CYLINDER ARM CAP	カマカハ - (クミ)	1
38	#03	B1411-804-A00	BEARING (A)	ハリクト - レハ - ハアリソク A	2
39	#03	B1411-804-B00	NEEDLE DRIVING LEVER BEARING B	ハリクト - レハ - ハアリソク B	2
40	#03	B1411-804-C00	NEEDLE DRIVING LEVER BEARING C	ハリクト - レハ - ハアリソク C	2
41	#03	B1411-804-D00	BEARING (D)	ハリクト - レハ - ハアリソク	2
42	#03	B1411-804-A00	BEARING (A)	ハリクト - レハ - ハアリソク A	1
43	#03	B1411-804-B00	NEEDLE DRIVING LEVER BEARING B	ハリクト - レハ - ハアリソク B	1
44	#03	B1411-804-C00	NEEDLE DRIVING LEVER BEARING C	ハリクト - レハ - ハアリソク C	1
45	#03	B1411-804-D00	BEARING (D)	ハリクト - レハ - ハアリソク	1
46		B1808-980-000	LOWER SHAFT THRUST WASHER	シタジク スラストワッシャー	1
47	#01	B1815-980-000	SHUTTLE UPPER SPRING	オオガ マウツハネ	1
48		B1815-210-000	INNER HOOK UPPER SPRING	オオガ マウツハネ	1
49		B1819-280-000	SHUTTLE RACE ADJUSTING SHAFT	オオガ マチヨセツジク	1
50		CS-1000811-SP	THRUST COLLAR	スラストウケ	1
51		SS-8110520-TP	SCREW 11/64-40 L= 4.5	トメネジ 11/64-40 L=4.5	2
52		CS-080081C-SH	THRUST COLLAR ASM. D=8.0 W=8	スラストウケ D=8 W=8 クミ	1
53		NS-6660430-SP	NUT 1/4-40	ロツカクナット 1/4-40	1
54		RE-0900000-KO	E-RING 9	Eカ タメワ 9	1
55		SD-0801021-TP	HINGE SCREW D= 8 H=10.2	タソネジ D=8 H=10.2	1
56		SS-6060410-TP	SCREW 3/32-56 L= 3.5	ヒラネジ 3/32-56 L=3.5	2
57		SS-6121212-TP	SCREW 3/16-28 L=12.0	ロツカクナット 3/16-28 L=12	1
58		SS-6151220-SP	SCREW 15/64-28 L=11.5	ヒラネジ 15/64-28 L=11.5	1
		NOTE (注記)	#01...FOR 210DSS, DSL	210DSS, DSL用	
			#02...FOR 210DHS, DHL	210DHS, DHL用	
			#03...SELECTIVE PART	選択部品	

From the library of: Diamond Needle Corp

7. WIPER MECHANISM COMPONENTS

ワイパ関係

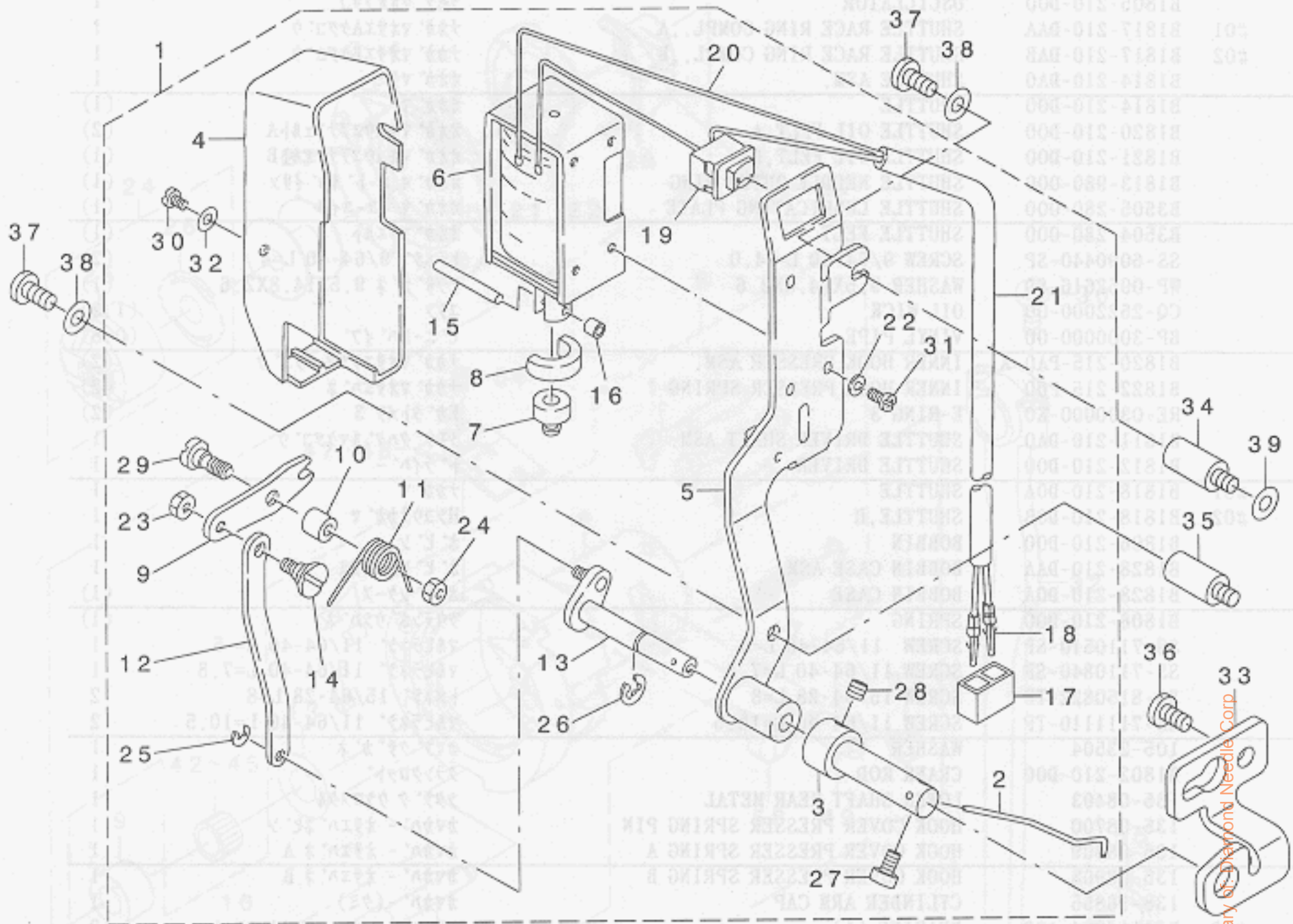

REF. NO	NOTE	PART NO.	DESCRIPTION	キ	リ	メ	イ	Qty
1		B2107-210-DAO	WIPER ASM.	ワイパ-組み				1
2		B2107-210-DOO	WIPER	ワイパ				(1)
3		B2111-210-DOO	WIPER SHAFT CAP	ワイパ-シャフトキャップ				(1)
4		110-72709	WIPER COVER	ワイパ-カバー				(1)
5		111-10152	WIPER BASE ASM.	ワイパ-ベース組み				(1)
6		111-10301	WIPER SOLENOID	ワイパ-ソレノイド				(1)
7		111-10400	WIPER RUBBER A	ワイパ-ゴム A				(1)
8		111-10509	WIPER RUBBER B	ワイパ-ゴム B				(1)
9		111-10608	WIPER LINK A	ワイパ-リンク A				(1)
10		111-10707	WIPER HINGE SCREW COLLAR	ワイパ-ダンパーネジカラー				(1)
11		111-10806	WIPER SPRING	ワイパ-バネ				(1)
12		111-10905	CONNECTING LINK	ワイパ-リンク B				(1)
13		111-11051	WIPER DRIVING SHAFT ASM.	ワイパ-駆動シャフト組み				(1)
14		111-11507	WIPER LINK B, HINGE SCREW	ワイパ-リンク B ダンパーネジ				(1)
15		111-12000	WIPER SOLENOID PIN	ワイパ-ソレノイドピン				(1)
16		111-11804	WIPER LINK COLLAR	ワイパ-リンクカラー				(1)
17		HK-0346100-20	2-POLE NYLON PLUG	プラグ 2P				(1)
18		HK-0346400-00	PIN CONTACT	ピンコンタクト				(2)
19		HA-0005900-00	POWER SWITCH	デンクオンスイッチ				(1)
20		HW-2003900-00	ELECTRIC WIRE	ビニール電線 17-0.16 3φ				(0.1)
21		HW-5000700-00	2-CORE CABTYRE CORD	2芯ケーブル				(1.2)
22		WS-0310002-KR	SPRING WASHER 3.1X5.9X0.7	バネワッシャー 3.1X5.9X0.7				(3)
23		NS-6090310-SP	NUT 9/64-40	ナット 9/64-40				(1)
24		NS-6110310-SP	NUT 11/64-40	ナット 11/64-40				(1)
25		RE-0250000-KO	E-RING 2.5	Eリング 2.5				(1)
26		RE-0500000-KO	E-RING	Eリング 5				(1)
27		SS-6090620-TP	SCREW	ビス				(1)
28		SS-8110422-TP	SCREW 11/64-40 L=4	ビス 11/64-40 L=4				(1)
29		SD-0650321-TP	HINGE SCREW D=6.5 H=3.2	ダンパーネジ D=6.5 H=3.2				(1)
30		SM-4030601-SN	SCREW M3 X 6	ナット M3X0.5 L=6				(1)
31		SM-4030601-SN	SCREW M3 X 6	ナット M3X0.5 L=6				(3)
32		WP-0320501-SC	WASHER M3	ワッシャー M3				(1)
33		B2110-210-DOO	WIPER SHAFT SUPPORT BRACKET	ワイパ-シャフト支持ブラケット				1
34		177-00402	FACE COVER JOINT	フェイスカバージョイント				1
35		B3549-850-000	LOOPER COVER OIL SHIELD STUD	ルーパーカバーオイルシールドスタッド				1
36		SS-7110840-SP	SCREW 11/64-40 L=7.8	ビス 11/64-40 L=7.8				2
37		SS-7110910-SP	SCREW 11/64-40 L=8.5	ビス 11/64-40 L=8.5				2
38		WP-0450801-SD	WASHER 4.5X10X0.8	ワッシャー 4.5X10X0.8				2
39		WP-0482086-SD	WASHER 4.8X11.5X2	ワッシャー 4.8X11.5X2				1

From the library of Raymond Needle Corp.

8. TENSION RELEASE & THREAD TENSION COMPONENTS

糸ゆるめ・糸調子関係

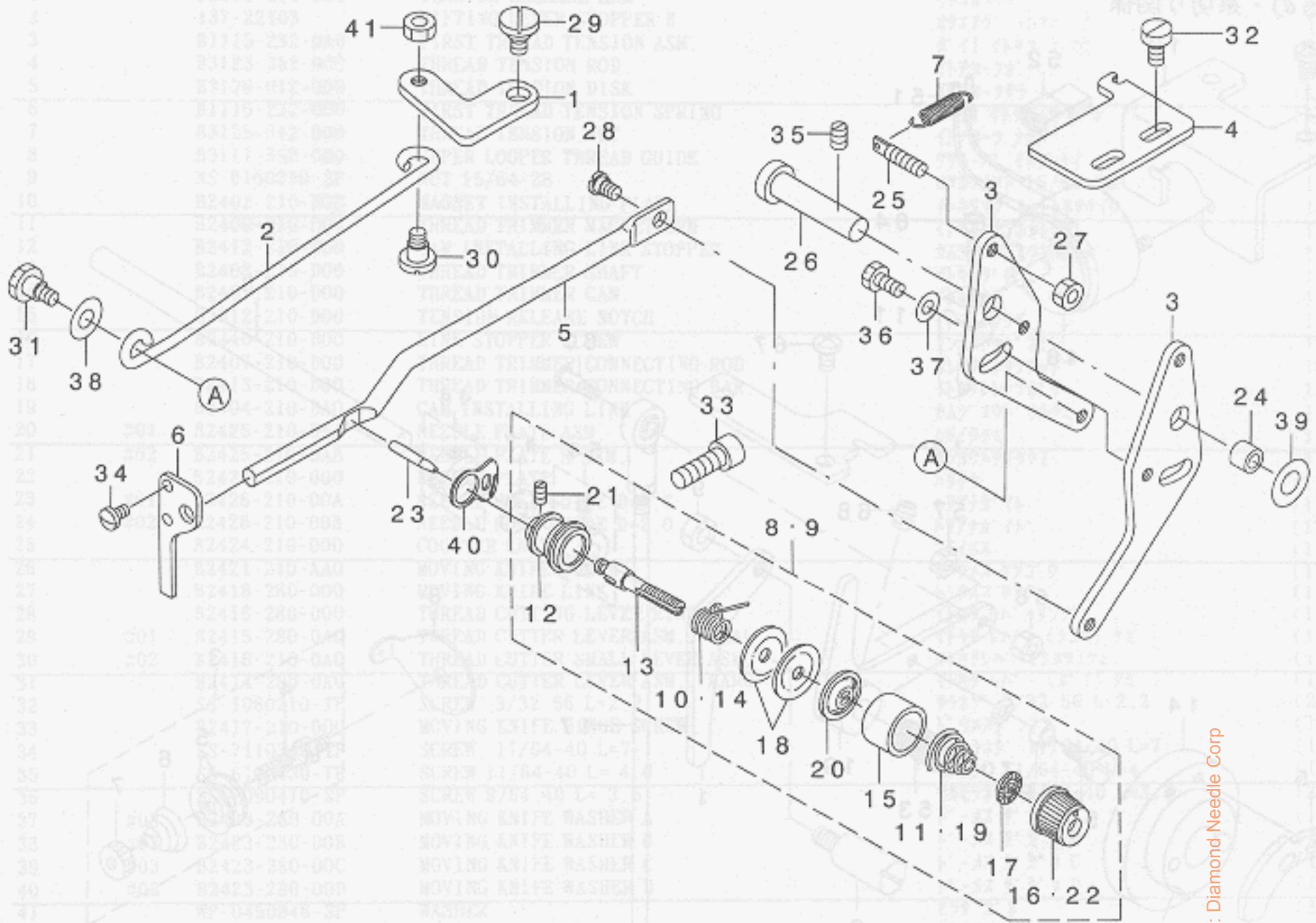

From the library of: Diamond Needle Corp

REF. NO	NOTE	PART NO.	DESCRIPTION	品名	Qty
1		B2304-210-D00	TENSION RELEASE LINK	トensionメリンク	1
2		B2308-210-D00	TENSION RELEASE CONNECTING ROD	トensionメリンクアサ	1
3		B2306-210-D00	TENSION RELEASE ADJUSTING ARM	トensionメッシュアーム	2
4		B2315-210-D00	STOPPER PLATE	トensionメッシュアームストップ	1
5		135-13205	TENSION RELEASE BAR	トensionリリースバー	1
6		135-13304	THREAD TENSION ARM	トensionアーム	1
7		137-16908	SPRING	スプリング	1
8	#01	B2302-280-0A0	SECOND THREAD TENSION ASM.	ダ イ 2 トension クミ	1
9	#02	B2302-205-0AA	SECOND THREAD TENSION,	ダ イ 2 トension イン トension クミ	1
10	#02	D3112-L4B-B00	TAKE-UP SPRING (HEAVY)	トension スプリング (キヤン)	(1)
11	#02	B2305-205-000	TENSION SPRING	ダ イ 2 トension スプリング	(1)
12		B2313-280-000	THREAD TENSION ROD, LARGE	トension ロッド (大)	(1)
13		B2302-280-000	SECOND THREAD TENSION ROD	ダ イ 2 トension ロッド	(1)
14	#01	B3112-761-000	THREAD TAKE-UP SPRING	トension スプリング	(1)
15	#01	B3107-804-000	THREAD TENSION DISK PRESSER	トension ディスクプレス	(1)
16	#01	B3119-771-000	THREAD TENSION NUT	トension ナット	(1)
17		B3120-125-000	ROTATING STOPPER	トension ストップ	(1)
18		B3126-012-000	THREAD TENSION DISK	トension ディスク	(2)
19	#01	B3114-232-000	THREAD TENSION SPRING	トension スプリング	(1)
20		B3132-552-000	THREAD TENSION DISK PRESSER	トension ディスクプレス	(1)
21		SS-8090610-SP	SCREW 9/64-40 L=5.9	スクリュー 9/64-40 L=5.9	(1)
22	#02	138-17408	THREAD TENSION NUT	トension ナット	(1)
23		B2303-280-000	TENSION RELEASE PIN	トension ピン	1
24		B2619-372-000	STOP MOTION TRIPPING LEVER CAM	ストップカム	1
25		B1649-161-000	TENSION SPRING ADJUSTING SCREW	スプリング調整スクリュー	1
26		D2431-555-B00	THREAD TRIMMER SHAFT	トension シャフト	1
27		NS-6110310-SP	NUT 11/64-40	ナット 11/64-40	1
28		SD-0530221-SP	HINGE SCREW D= 5.3 H= 2.2	ヒンジスクリュー D=5.3 H=2.2	1
29		SD-0720321-TP	HINGE SCREW	ヒンジスクリュー	1
30		SD-0640391-TP	HINGE SCREW D= 6.35 H= 3.9	ヒンジスクリュー D=6.35 H=3.9	1
31		SD-0640482-SP	HINGE SCREW D= 6.35 H= 4.8	ヒンジスクリュー D=6.35 H=4.8	1
32		SS-6120940-SP	SCREW 3/16-28 L=9	スクリュー 3/16-28 L=9	2
33		SS-6151812-TP	SCREW 15/64-28 L=18	スクリュー 15/64-28 L=18	1
34		SS-7090620-TP	SCREW 9/64-40 L=6.1	スクリュー 9/64-40 L=6.1	2
35		SS-8120740-SP	SCREW 3/16-28 L=7	スクリュー 3/16-28 L=7	1
36		SS-9110920-CP	SCREW 11/64-40 L=9	スクリュー 11/64-40 L=9	1
37		WP-0482086-SD	WASHER 4.8X11.5X2	ワッシャー 4.8X11.5X2	1
38		WP-0651056-SD	WASHER 6.5X11X1	ワッシャー 6.5X11X1	1
39		WP-0841600-SE	WASHER 8.4X15.5X1.6	ワッシャー 8.4X15.5X1.6	1
40		B2702-210-000	GUIDE PLATE	ガイドプレート	1
41		NS-6120310-SP	NUT 3/16-28	ナット 3/16-28	1

NOTE (注記)

#01... FOR 210DSS, DSL
#02... FOR 210DHS, DHL

210DSS, DSL用
210DHS, DHL用

9. TENSION RELEASE & TEREAD TRIMMER MECHANISM COMPONENTS

糸ゆるめ・糸切り関係
糸ゆるめ・糸切り関係

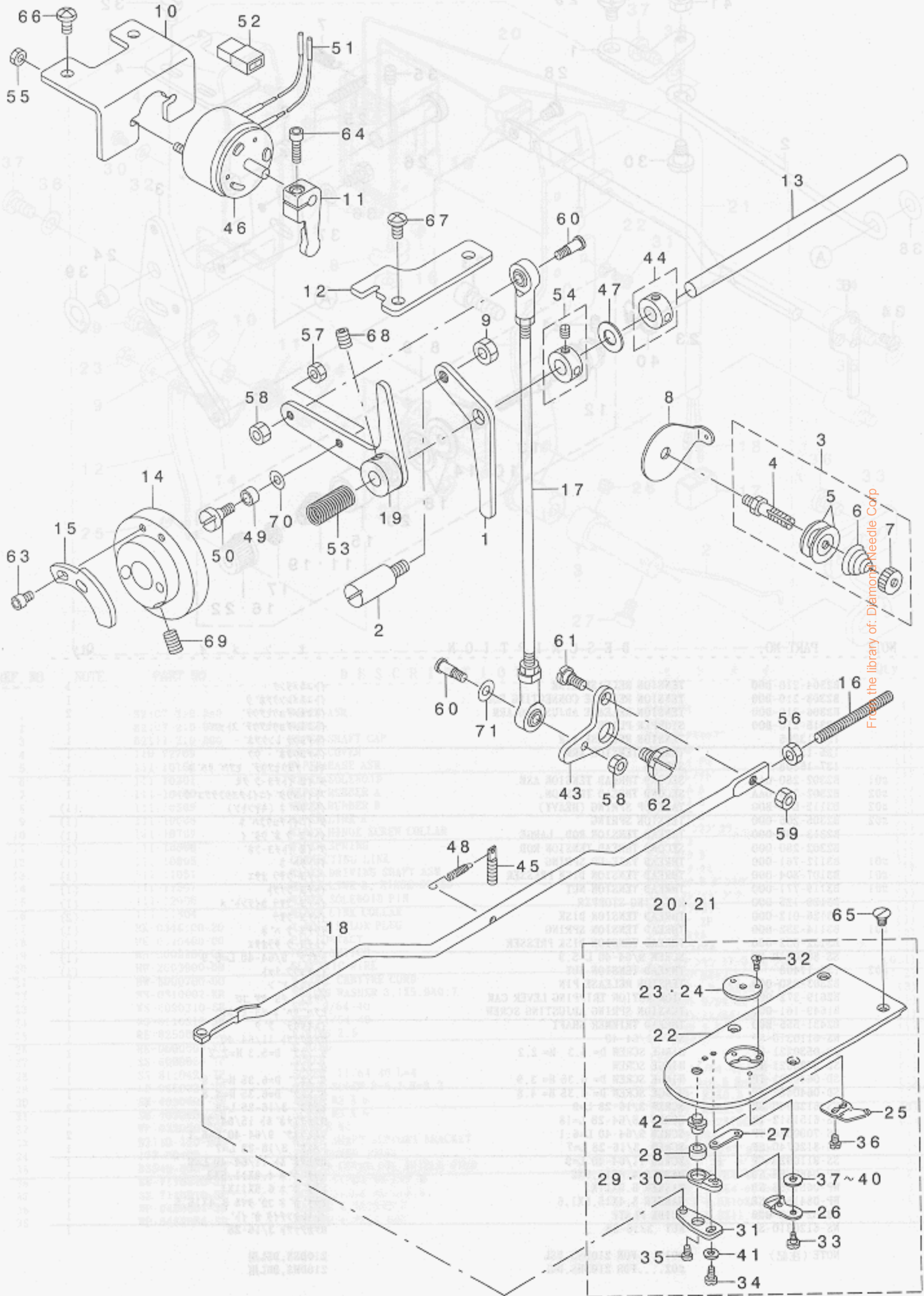

From the library of: Diamond Needle Corp

REF. NO	NOTE	PART NO.	DESCRIPTION	ヒョウメイ	Qty
1		B2301-210-D00	TENSION RELEASE ARM	トコルメウデ	1
2		137-22103	LIFTING LEVER STOPPER B	オサエアケ ストッパ B	1
3		B1115-232-0A0	FIRST THREAD TENSION ASM.	ダイ1 トチヨ-シ クミ	1
4		B3123-352-000	THREAD TENSION ROD	トチヨ-シホ	(1)
5		B3126-012-000	THREAD TENSION DISK	トチヨ-シハラ	(2)
6		B1115-232-000	FIRST THREAD TENSION SPRING	ダイ1 トチヨ-シ ハネ	(1)
7		B3125-012-000	THREAD TENSION NUT	トチヨ-シ ナツト	(1)
8		B3111-352-000	UPPER LOOPER THREAD GUIDE	ウツルハ トアンナイ イタ	1
9		NS-6150310-SP	NUT 15/64-28	ロツカクナツト 15/64-28	1
10		B2402-210-D00	MAGNET INSTALLING PLATE	トキリマク ネットトリツケイタ	1
11		B2409-210-D00	THREAD TRIMMER MAGNET ARM	トキリマク ネットウデ	1
12		B2412-210-D00	CAM INSTALLING LINK STOPPER	カムシ ユウト ウツストップ	1
13		B2408-210-D00	THREAD TRIMMER SHAFT	トキリシク	1
14		B2401-210-D00	THREAD TRIMMER CAM	トキリカム	1
15		B2312-210-D00	TENSION RELEASE NOTCH	トコルメノツチ	1
16		B2440-210-D00	LINK STOPPER SCREW	リンクストップ ネジ	1
17		B2407-210-D00	THREAD TRIMMER CONNECTING ROD	トキリリンクケツロツト	1
18		B2413-210-D00	THREAD TRIMMER CONNECTING BAR	トキリリンクケツホ ウ	1
19		B2404-210-DA0	CAM INSTALLING LINK	カムシ ユウト ウツクミ	1
20	#01	B2425-210-DAA	NEEDLE PLATE ASM.	ハリイタクミ	1
21	#02	B2425-210-DAB	NEEDLE PLATE H ASM.	Hシヨウハリイタクミ	1
22		B2425-210-000	NEEDLE PLATE	ハリイタ	(1)
23	#01	B2426-210-00A	NEEDLE HOLE GUIDE D=1.6	ハリアナカ イト	(1)
24	#02	B2426-210-00B	NEEDLE HOLE GUIDE D=2.0	ハリアナカ イト	(1)
25		B2424-210-000	COUNTER KNIFE	コテイメス	(1)
26		B2421-210-AA0	MOVING KNIFE COMPL.	ト ウメス ケツゴウ	(1)
27		B2418-280-000	MOVING KNIFE LINK	ト ウメス リンク	(1)
28		B2416-280-000	THREAD CUTTING LEVER RING	トキリレハ リンク	(1)
29	#01	B2415-280-0A0	THREAD CUTTER LEVER ASM., SMAL	トキリレハ (シヨウ) クミ	(1)
30	#02	B2416-210-0A0	THREAD CUTTER SMALL LEVER ASM.	トキリレハ (シヨウ)クミ	(1)
31		B2414-280-0A0	THREAD CUTTER LEVER ASM., LARG	トキリレハ (ダイ)クミ	(1)
32		SS-1060210-TP	SCREW 3/32-56 L=2.2	サラネジ 3/32-56 L=2.2	(2)
33		B2417-210-000	MOVING KNIFE HINGE SCREW	ト ウメスタ ソネジ	(1)
34		SS-7110740-TP	SCREW 11/64-40 L=7	マルヒラネジ 11/64-40 L=7	(1)
35		SS-6110430-TP	SCREW 11/64-40 L= 4.0	ヒラネジ 11/64-40 L=4	(1)
36		SS-7090410-SP	SCREW 9/64-40 L= 3.5	マルヒラネジ 9/64-40 L=3.5	(2)
37	#03	B2423-280-00A	MOVING KNIFE WASHER A	ト -メス サカネ A	(1)
38	#03	B2423-280-00B	MOVING KNIFE WASHER B	ト -メス サカネ B	(1)
39	#03	B2423-280-00C	MOVING KNIFE WASHER C	ト -メス サカネ C	(1)
40	#03	B2423-280-00D	MOVING KNIFE WASHER D	ト -メス サカネ D	(1)
41		WP-0450846-SP	WASHER	ヒラサカネ	(1)
42		B2417-280-000	THREAD CUTTER LEVER SHAFT	トキリレハ シク	(1)
43		B2411-210-000	THREAD TRIMMER LINK	トキリ リンク	1
44		CS-080081C-SH	THRUST COLLAR ASM. D=8.0 W=8	スラストウケ D=8 W=8 クミ	1
45		B1649-161-000	TENSION SPRING ADJUSTING SCREW	ヒツハ リハ ネ チヨセツネジ	1
46		B2303-205-000	SOLENOID	トコルメマク ネット	1
47		B1116-804-000	CLOTH PLATE WASHER	ヌノダ イサ	1
48		B2431-215-000	THREAD TRIMMER LINK SPRING	トキリ リンクハネ	1
49		D2587-L8W-B00	ROLLER	外 -カム コロ	1
50		D2588-L8W-B00	ROLLER SHAFT	外 -カム コロシク	1
51		HK-0346300-00	TERMINAL	ピンターミナル オス	2
52		HK-0346200-20	2P PLUG	プラグ 2P	1
53		B2617-771-000	TRIPPING LEVER TENSION SPRING	フツク ヒキハズ シレハ -ハネ	1
54		CS-080081C-SH	THRUST COLLAR ASM. D=8.0 W=8	スラストウケ D=8 W=8 クミ	1
55		NM-6040003-SC	NUT M4	ロツカクナツト M4	2
56		NM-6050001-SP	NUT M5	ロツカクナツト M5X0.8 1ツコ	1
57		NS-6110310-SP	NUT 11/64-40	ロツカクナツト 11/64-40	1
58		NS-6110420-SP	NUT 11/64-40	ロツカクナツト 11/64-40	2
59		NS-6120630-SP	NUT 3/16-28	ロツカクナツト 3/16-28	1
60		SD-0500803-TP	HINGE SCREW D=5 H=8	ダイソネジ D=5 H=8	2
61		SD-0650305-TP	HINGE SCREW D= 6.5 H= 3	ダイソネジ D=6.5 H=3	1
62		SD-1100301-TP	HINGE SCREW H=11 W=3	ダイソネジ H=11 W=3	1
63		SM-6040602-TP	SCREW M4 L=6	ロツカクアサホ ルト M4X0.7 L=6	2
64		SM-6041402-TP	SCREW M4 L=14	ロツカクアサホ ルト M4	1
65		SS-1110640-TP	SCREW 11/64-40 L= 5.5	サラネジ 11/64-40 L=5.5	4
66		SS-4120915-SP	SCREW 3/16-28 L=9	ナハネジ 3/16-28 L=9	2
67		SS-4120915-SP	SCREW 3/16-28 L=9	ナハネジ 3/16-28 L=9	2
68		SS-8150822-TP	SCREW 15/64-28 L=8	トメネジ 15/64-28 L=8	1
69		SS-8661012-TP	SCREW	トメネジ	2
70		WP-0450846-SP	WASHER	ヒラサカネ	1
71		WP-0501016-SD	WASHER 5X10.5X1	ヒラサカネ 5X10.5X1	1

NOTE (注記) #01...FOR 210DSS,DSL
#02...FOR 210DHS,DHL
#03...SELECTIVE PART

210DSS,DSL用
210DHS,DHL用
選択部品

From the library of: Diamond Needle Corp

10. X-Y COMPONENTS (1)

X-Y関係(1)

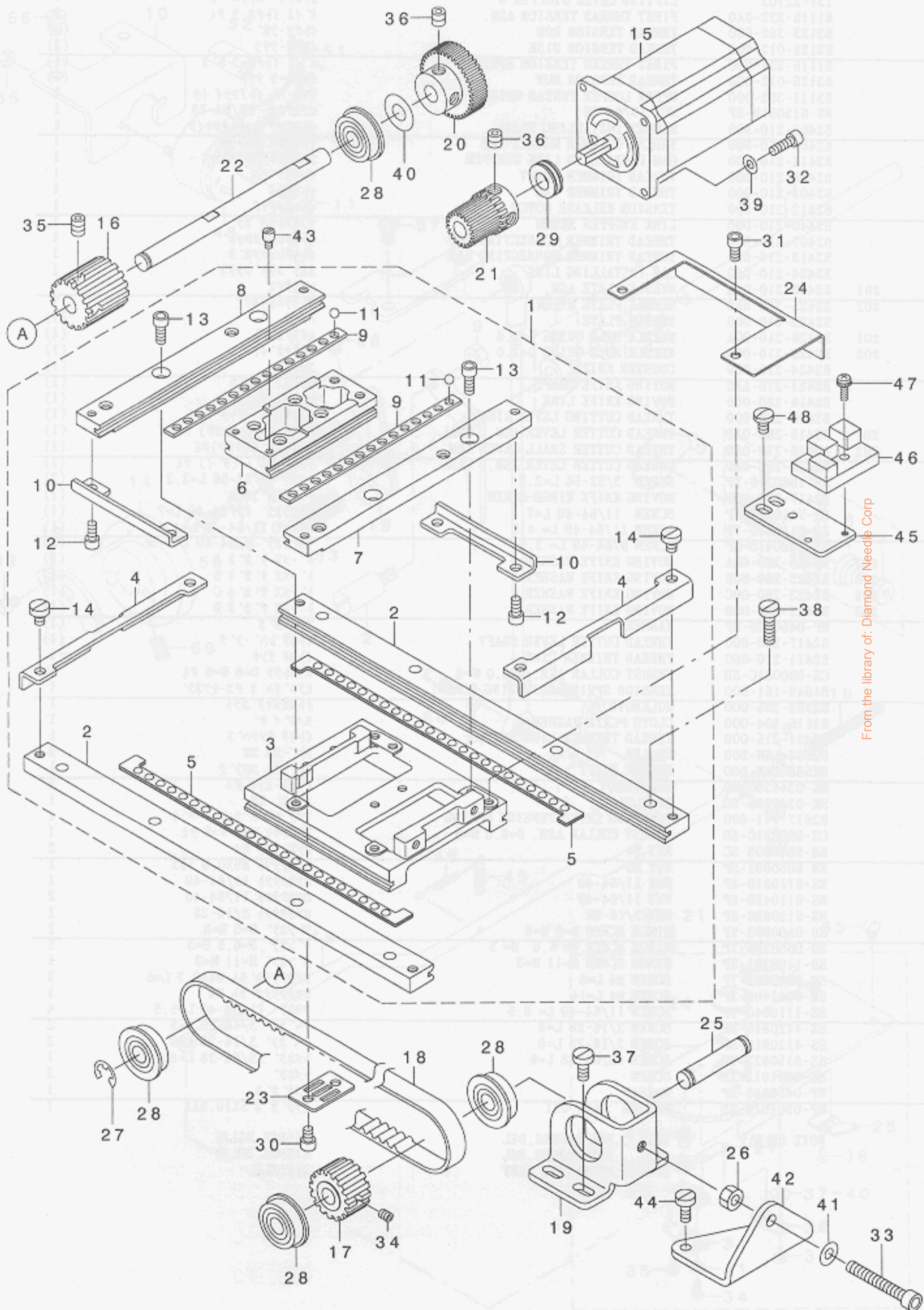

From the library of: Diamond Needle Corp

REF. NO	NOTE	PART NO.	DESCRIPTION	ヒョウメイ	Qty
1		B2501-210-DA0	X-Y TABLE ASM.	X-Yテーブルユニット	1
2		B2501-210-D00	X FIXED RACE	Xコティレース	(2)
3		B2502-210-D00	RACE TABLE	レーステーブル	(1)
4		B2507-210-D00	X STOPPER	Xストッパ	(2)
5		B2508-210-DA0	X BALL GAUGE ASM.	Xボールゲージクミ	(2)
6		B2519-210-D00	Y REMOVAL RACE	Yイトウレース	(1)
7		B2520-210-DOA	Y FIXED RACE, RIGHT	Yコティレースミキ	(1)
8		B2520-210-DOB	Y FIXED RACE, LEFT	Yコティレースヒタリ	(1)
9		B2521-210-D00	Y BALL GAUGE	Yボールゲージ	(2)
10		B2522-210-D00	Y STOPPER	Yストッパ	(2)
11		B2527-210-000	BALL	テーブルボール	(30)
12		SM-6040802-TP	SCREW M4X0.7 L=8	ロツカクアナボルト	(4)
13		SM-6041002-TP	SCREW M4 L=10	ロツカクアナボルト M4X0.7 L=10	(4)
14		SS-6110610-TP	SCREW 11/64-40 L=6	ヒラネジ 11/64-40 L=6	(4)
15		B2529-210-D00	FEED STEPPING MOTOR	オクリステッピングモータ	1
16		B2513-210-D00	DRIVE SPROCKET	クトウズブロケット	1
17		B2514-210-D00	DRIVEN SPROCKET	ジユウトウズブロケット	1
18		B2512-210-D00	X TIMING BELT	Xタイミングベルト	1
19		B2505-210-D00	X DRIVEN BRACKET	Xジユウトウブラケット	1
20		B2534-210-D00	X DRIVEN GEAR	Xジユウトウウハグルマ	1
21		B2526-210-D00	X DRIVE GEAR	Xクトウウハグルマ	1
22		B2506-210-D00	X DRIVE SHAFT	Xクトウシャク	1
23		B2509-210-D00	BELT RECEIVER	ベルトオサエ	1
24		B4007-210-D00	X SENSOR SLIT	Xセンサスリット	1
25		135-18105	LIFTING LEVER SHAFT	ヌノオサエアケレバシク	1
26		NM-6050001-SP	NUT M5	ロツカクナツト M5X0.8 1シユ	1
27		RE-0600000-KO	E-RING 6	Eカートメワ 6	1
28		SB-1080005-00	RADIAL BEARING	ラジアルベリクウク	4
29		SB-4080001-00	BEARING	コロカベリクウク	1
30		SM-6040602-TP	SCREW M4 L=6	ロツカクアナボルト M4X0.7 L=6	2
31		SM-6040602-TP	SCREW M4 L=6	ロツカクアナボルト M4X0.7 L=6	2
32		SM-6041202-TP	SCREW M4X0.7 L=12	ロツカクアナボルト	4
33		SM-6053502-TP	BOLT	ロツカクアナボルト	1
34		SM-8040502-TP	SCREW M4X0.7 L=5	トメネジ M4X0.7 L=5	1
35		SM-8060802-TP	SCREW M6 L=8	トメネジ M6 L=8	2
36		SM-8060602-TP	SCREW M6X6	トメネジ M6 L=6	4
37		SS-6111010-SP	SCREW 11/64-40 L= 9.5	ヒラネジ 11/64-40 L=9.5	4
38		SS-6111620-SP	SCREW 11/64-40 L=16.0	ヒラネジ 11/64-40 L=16	8
39		WP-0450846-SP	WASHER	ヒラサカネ	4
40		WP-0820526-SD	WASHER 8.2X14X0.5	ヒラサカネ 8.2X14X0.5	1
41		WP-0531001-SC	WASHER	ヒラサカネ ミカキマル M5	1
42		B2530-210-D00	X BELT ADJUSTING BRACKET	Xベルトチヨウリヨクチヨウセイブラケット	1
43		B1519-026-00G	HINGE STUD	ヒンジシク	2
44		SS-6111010-SP	SCREW 11/64-40 L= 9.5	ヒラネジ 11/64-40 L=9.5	2
45		B4004-210-D00	X SENSOR INSTALLING PLATE	Xセンサトリツケイタ	1
46		HD-0005700-0A	PHOTO SENSOR	フォトセンサ	1
47		SL-4031081-SF	SCREW M3 L=10	ナベコネジ セス M3 L=10	1
48		SS-7110710-SP	SCREW 11/64-40 L=7	マルヒラネジ 11/64-40 L=7	2

11. X-Y COMPONENTS (2)

X-Y関係(2)

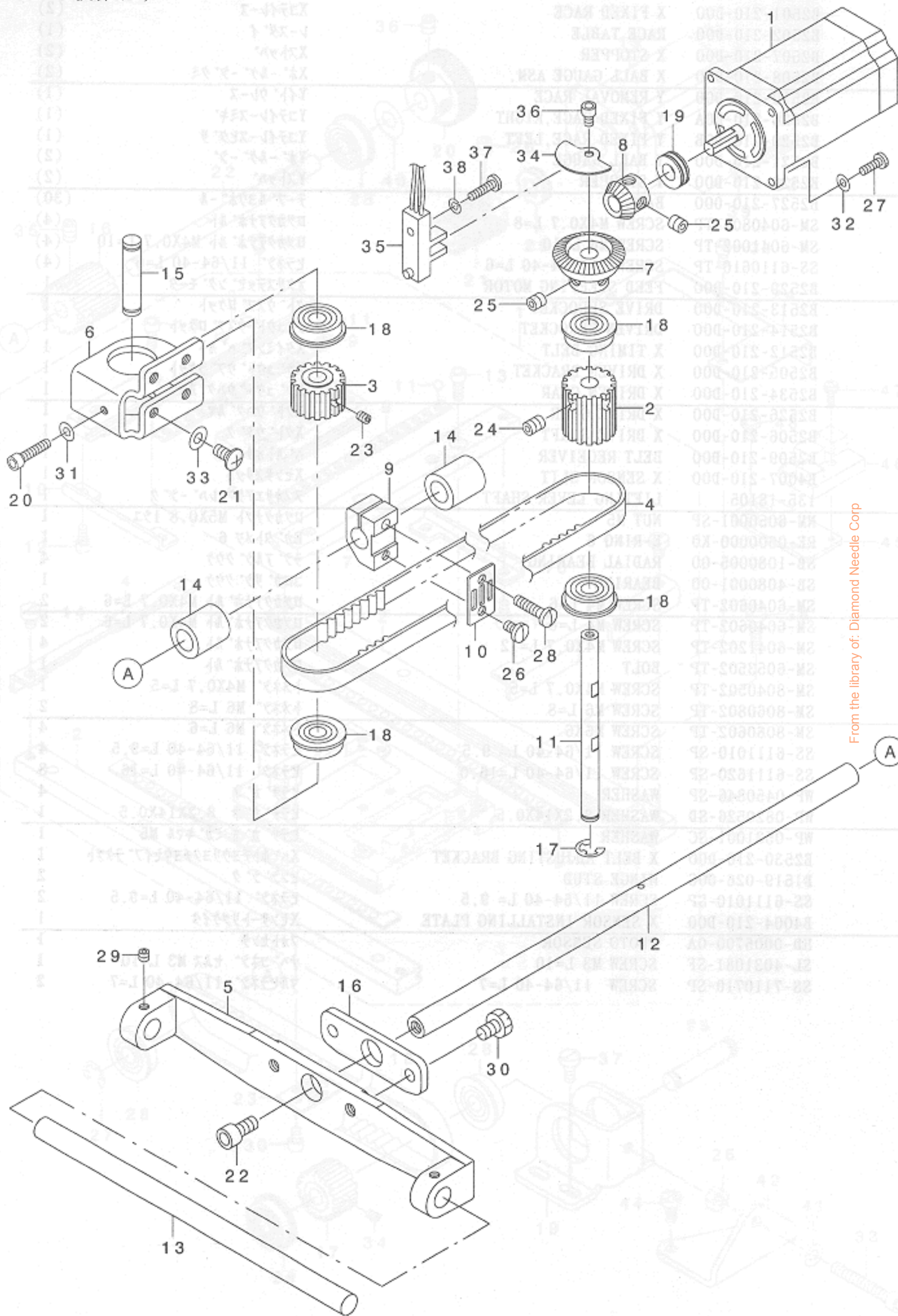

From the library of: Diamond Needle Corp

REF. NO	NOTE	PART NO.	DESCRIPTION	トヨタ	Qty
1		B2529-210-D00	FEED STEPPING MOTOR	オクリステッピングモータ	1
2		B2513-210-D00	DRIVE SPROCKET	クトウズブロケット	1
3		B2514-210-D00	DRIVEN SPROCKET	シユウトウズブロケット	1
4		B2528-210-D00	Y TIMING BELT	Yタイミングベルト	1
5		B2511-210-D00	X GUIDE SHAFT BRACKET	Xガイドシャフトササエ	1
6		B2518-210-D00	Y DRIVEN BRACKET	Yシユウトウブラケット	1
7		B2548-210-D00	Y DRIVEN GEAR	Yシユウトウウハクギ	1
8		B2525-210-D00	Y DRIVE GEAR	Yクトウウハクギ	1
9		B2536-210-D00	Y BELT BRACKET	Yベルトタイ	1
10		B2509-210-D00	BELT RECEIVER	ベルトオサエ	1
11		B2523-210-D00	Y DRIVE SHAFT	Yクトウシャフト	1
12		B2524-210-D00	Y REMOVAL SHAFT	Yイトウシャフト	1
13		B2510-210-D00	X GUIDE SHAFT	Xガイドシャフト	1
14		B2509-704-000	BUSHING, REAR	ルハシクウシロメタル	2
15		135-18105	LIFTING LEVER SHAFT	スノオサエアケレバシク	1
16		B2525-205-000	Y REMOVAL BRACKET	Yイトウシャフトクイタ	1
17		RE-0600000-K0	E-RING 6	Eガイドメツ	1
18		SB-1080005-00	RADIAL BEARING	ラジアルベアリング	4
19		SB-4080001-00	BEARING	コロベアリング	1
20		SM-6041802-TP	SCREW M4 L=18	ロツカクアホルト	1
21		SM-0051001-SC	SCREW	トラスネジ M5 L=10	4
22		SM-6061202-TP	SCREW M6 L=12	ロツカクアホルト M6 L=12	1
23		SM-8040502-TP	SCREW M4X0.7 L=5	トメネジ M4X0.7 L=5	1
24		SM-8060802-TP	SCREW M6 L=8	トメネジ M6 L=8	2
25		SM-8060602-TP	SCREW M6X6	トメネジ M6 L=6	4
26		SS-7110720-SP	SCREW 11/64-40 L=7	マルヒラネジ 11/64-40 L=7	1
27		SS-7091110-SP	SCREW 9/64-40 L=10.5	マルヒラネジ 9/64-40 L=10.5	4
28		SS-7111810-TP	SCREW 11/64-40 L=18	マルヒラネジ 11/64-40 L=18	1
29		SS-8110422-TP	SCREW 11/64-40 L=4	トメネジ 11/64-40 L=4	2
30		SS-9150910-SP	SCREW	ロツカクホルト	2
31		WP-0430801-SC	WASHER 4.3X9X0.8	ヒラサカネ 4.3X9X0.8	1
32		WP-0450846-SP	WASHER	ヒラサカネ	4
33		WP-0551016-SH	WASHER 5.5X13X1	ヒラサカネ 5.5X13X1	4
34		B4008-210-D00	Y SENSOR SLIT	Yセンサーリット	1
35		HD-0013500-00	SENSOR	センサ	1
36		SM-6040602-TP	SCREW M4 L=6	ロツカクアホルト M4X0.7 L=6	1
37		SS-7091410-SP	SCREW 9/64-40 L=13.5	マルヒラネジ 9/64-40 L=13.5	1
38		WS-0410002-KP	SPRING WASHER	ハネサカネ M4	1

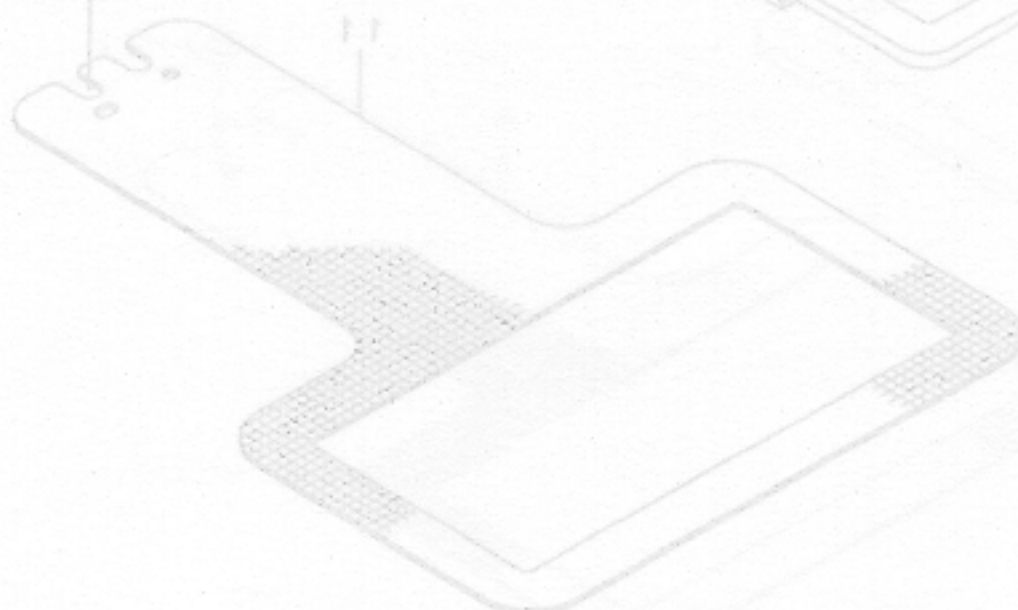

From the library of: Diamond Needle Corp

12. CLOTH FEED MECHANISM COMPONENTS(FOR 210DSS,210DHS)

布送り台関係 (210DSS, 210DHS用)

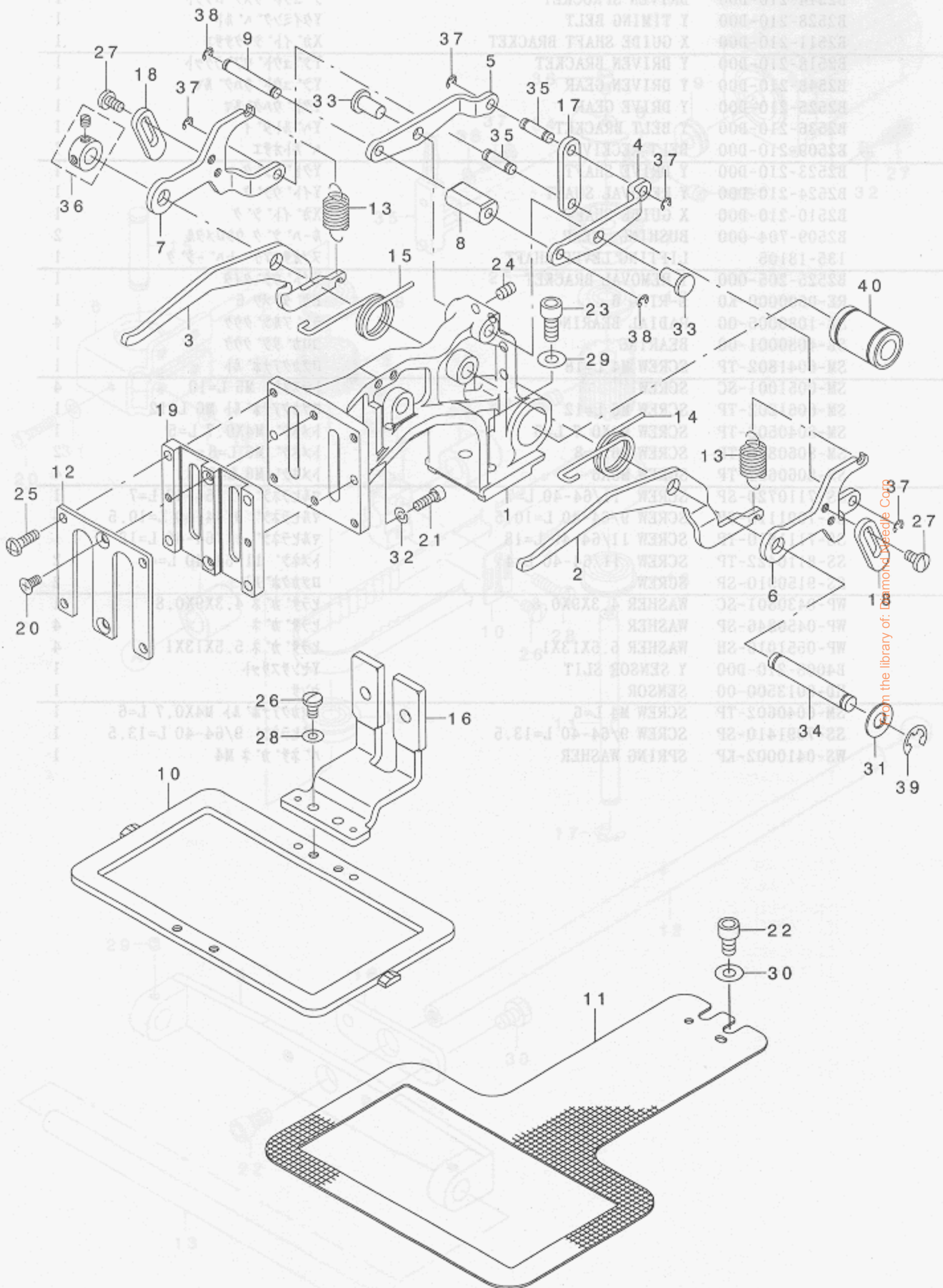

REF. NO	NOTE	PART NO.	DESCRIPTION	ヒョウメ	Qty
1		B2550-210-D00	FEED BRACKET	ヌノオクリタ イ	1
2		B2570-210-D00	LIFTING LEVER, RIGHT	オサエリンクミキ	1
3		B2571-210-D00	LIFTING LEVER, LEFT	オサエリンクヒタ リ	1
4		B2577-210-D00	FEED BRACKET UPPER LINK, RIGHT	オクリタ イウエリンクミキ	1
5		B2578-210-D00	FEED BRACKET UPPER LINK, LEFT	オクリタ イウエリンクヒタ リ	1
6		B2574-210-D00	SUPPORT LINK, RIGHT	オクリタ イホシ ヨリンクミキ	1
7		B2575-210-D00	SUPPORT LINK, LEFT	オクリタ イホシ ヨリンクヒタ リ	1
8		B2579-210-D00	SLIDER	スライダ	1
9		B2573-210-D00	SLIDER SHAFT	スライダ -ジ ク	1
10		B2553-210-D00	FEEDING FRAME	ヌノオサエソトワク	1
11		B2552-210-D00	FEED PLATE	シタイタ	1
12		B2572-210-D00	WORK CLAMP FOOT PLATE COVER	ヌノオサエスハ リイタフタ	1
13		B2583-210-D00	SPRING	オサエハ ネ	2
14		B2581-210-D00	SPRING, RIGHT	オサエモト シハ ネミキ	1
15		B2582-210-D00	SPRING, LEFT	オサエモト シハ ネヒタ リ	1
16		B2551-210-DA0	WORK CLAMP FOOT COMPL.	イツタイヌノオサエアシスハ リイタケツゴ ウ	1
17		B2576-210-D00	FEED BRACKET LINK	オクリタ イリンク	1
18		B2580-210-D00	LINK STOPPER	リンクストツハ	2
19		B2610-210-D00	WORK CLAMP FOOT PLATE	ヌノオサエスハ リイタ	1
20		SM-1040801-SP	SCREW M4X0.7 L=8	サラコネシ M4X0.7 L=8	2
21		SM-6041202-TP	SCREW M4X0.7 L=12	ロツカクアナホ ルト	2
22		SM-6061002-TP	SCREW M6 L=10	ロツカクアナホ ルト M6 L=10	2
23		SM-6061402-TN	BOLT	ロツカクアナホ ルト	2
24		SM-8050802-TP	SCREW M5X0.8 L=8	トメネシ M5X0.8 L=8	2
25		SS-4111415-SP	SCREW 11/64-40 L=14	ナハ ネシ 11/64-40 L=14	4
26		SS-7110840-SP	SCREW 11/64-40 L=7.8	マルヒラネシ 11/64-40 L=7.8	2
27		SS-7110840-SP	SCREW 11/64-40 L=7.8	マルヒラネシ 11/64-40 L=7.8	4
28		WP-0480856-SP	WASHER 4.8X8.4X0.8	ヒラサ カ ネ 4.8X8.4X0.8	2
29		WP-0651001-SC	WASHER	ヒラサ カ ネ	2
30		WP-0651001-SC	WASHER	ヒラサ カ ネ	2
31		B2557-280-00C	WASHER	ヨコオクリウテ サ カ ネ C	1
32		WS-0410002-KP	SPRING WASHER	ハ ネサ カ ネ M4	2
33		B1626-555-000	FEED REGULATOR CONNECTING ROD	オクリ チヨセツキ ロツト ヒソ	2
34		D2502-232-D00	SHAFT BLOCK SHAFT	ツマミソチ トリツケシ ク	1
35		B1626-220-000	CYLINDER PIN	シリンドラ セツソ クヒソ	2
36		CS-079073A-SH	THRUST COLLAR ASM.	スラストウケ クミ	1
37		RE-0300000-K0	E-RING 3	Eカ タメワ 3	4
38		RE-0300000-K0	E-RING 3	Eカ タメワ 3	2
39		RE-0700000-K0	E-RING 7	Eカ タメワ 7	1
40		SB-7100002-00	SLIDE BEARING	スライト シ クウケ	1

From the library of: Diamond Needle Corp.



13. CLOTH FEED MECHANISM COMPONENTS(FOR 210DSL,210DHL)

布送り台関係 (210DSL, 210DHL用)

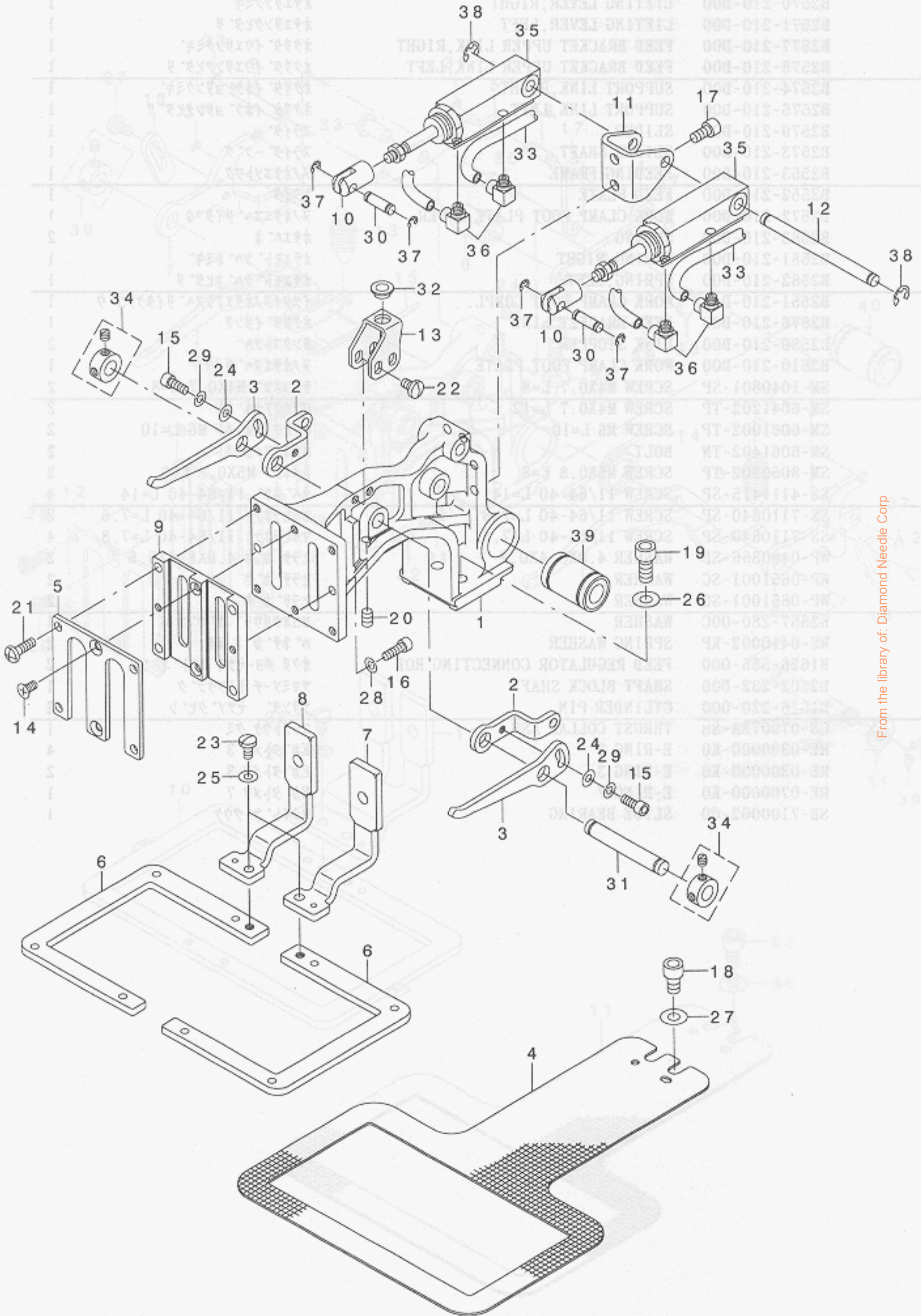

REF. NO	NOTE	PART NO.	DESCRIPTION	ヒョウメイ	Qty
1		B2550-210-D00	FEED BRACKET	ヌノオクリタ イ	1
2		B2564-210-D00	LINK PLATE A	オサエリンクイタA	2
3		B2560-210-D00	LINK PLATE B	オサエリンクイタB	2
4		B2552-210-D00	FEED PLATE	シタイタ	1
5		B2572-210-D00	WORK CLAMP FOOT PLATE COVER	ヌノオサエスハ リイタフタ	1
6		B2554-210-D00	FEEDING FRAME	2タ ノオサエヨウヌノオサエソトワク	2
7		B2590-210-DA0	WORK CLAMP FOOT COMPL., RIGHT	ヌノオサエアシスハ リイタミキ ケツコ ウ	1
8		B2591-210-DA0	WORK CLAMP FOOT COMPL., LEFT	ヌノオサエアシスハ リイタヒタ リケツコ ウ	1
9		B2610-210-D00	WORK CLAMP FOOT PLATE	ヌノオサエスハ リイタ	1
10		B2566-210-D00	CYLINDER KNUCKLE	オサエシリシタ ナツクル	2
11		B2567-210-D00	CYLINDER INSTALLING BASE	シリシタ トリツケタ イ	1
12		B2561-210-D00	CYLINDER SHAFT	オサエシリシタ シク	1
13		B2562-210-D00	SLIDER BASE	スライタ ーダ イ	1
14		SM-1040801-SP	SCREW M4X0.7 L=8	サヲコネシ M4X0.7 L=8	2
15		SM-6041002-TP	SCREW M4 L=10	ロツカクアナホ ルト M4X0.7 L=10	2
16		SM-6041202-TP	SCREW M4X0.7 L=12	ロツカクアナホ ルト	2
17		SM-6051002-TP	SCREW M5X0.8 L=10	ロツカクアナホ ルト M5X0.8 L=10	2
18		SM-6061002-TP	SCREW M6 L=10	ロツカクアナホ ルト M6 L=10	2
19		SM-6061402-TN	BOLT	ロツカクアナホ ルト	2
20		SM-8050812-TP	SCREW M5X8	トメネシ M5X0.8 L=8	1
21		SS-4111415-SP	SCREW 11/64-40 L=14	ナハネシ 11/64-40 L=14	4
22		SS-7110710-SP	SCREW 11/64-40 L=7	マルヒラネシ 11/64-40 L=7	4
23		SS-7110840-SP	SCREW 11/64-40 L=7.8	マルヒラネシ 11/64-40 L=7.8	2
24		WP-0450000-SD	WASHER 4.5X8X0.5	ヒラサカネ 4.5X8X0.5	2
25		WP-0480856-SP	WASHER 4.8X8.4X0.8	ヒラサカネ 4.8X8.4X0.8	2
26		WP-0651001-SC	WASHER	ヒラサカネ	2
27		WP-0651001-SC	WASHER	ヒラサカネ	2
28		WS-0410002-KP	SPRING WASHER	ハネサカネ M4	2
29		WS-0410002-KP	SPRING WASHER	ハネサカネ M4	2
30		B1626-220-000	CYLINDER PIN	シリシタ セツソクヒソ	2
31		D2502-232-D00	SHAFT BLOCK SHAFT	ツマミソチ トリツケシク	1
32		G5126-172-000	CLAMP SHAFT HOLDER	クランプ シクウケ	1
33		BT-0400251-EB	URETHANE HOSE, BLACK	ウレタンホース クロ	4
34		CS-079073A-SH	THRUST COLLAR ASM.	スラストウケ クミ	2
35		PA-1602006-A0	AIR CYLINDER	エアシリシタ	2
36		PJ-0460525-03	HOSE ELBOW	ホース エルボ	4
37		RE-0300000-K0	E-RING 3	Eガ タメワ 3	4
38		RE-0500000-K0	E-RING	Eガ タメワ 5	2
39		SB-7100002-00	SLIDE BEARING	スライト シクウケ	1



From the library of: Diamond Needle Corp.

14. PNEUMATIC COMPONENTS(FOR 210DSL,210DHL)

エア関係 (210DSL, 210DHL用)

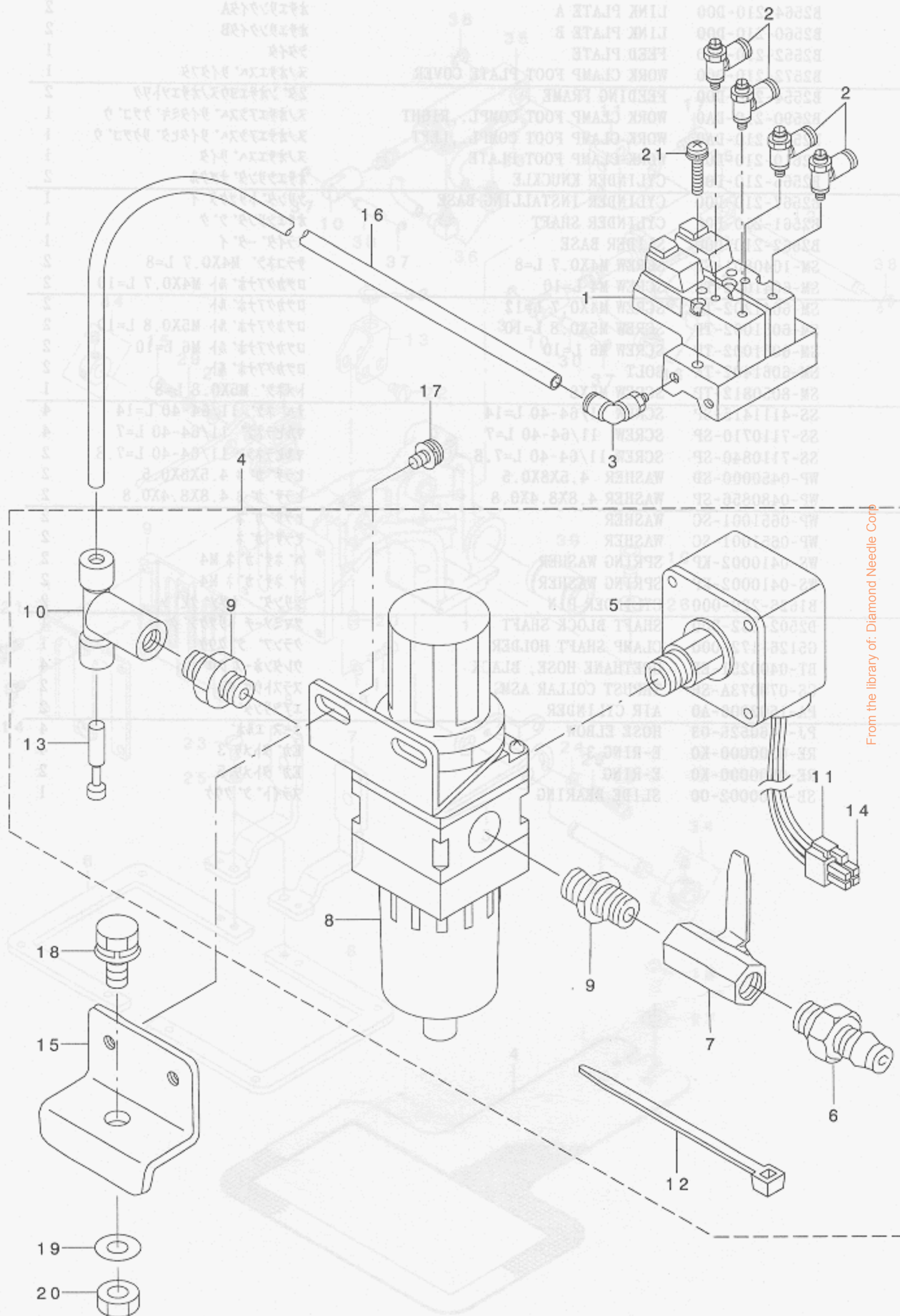

From the library of: Diamond Needle Corp

REF. NO	NOTE	PART NO.	DESCRIPTION	品名	Qty
1		PV-0351130-A0	SOLENOID VALVE ASM.	ソレノイドバルブ組立	1
2		PC-0105070-00	SPEED CONTROLLER	スピードコントローラ	4
3		PJ-3040651-01	ELBOW UNION 6XPT1/8	エルボユニオン 6XPT1/8	1
4		B4715-215-0A0	FILTER REGULATOR ASM.	フィルタレギュレータ組立	1
5		G8124-270-000	AIR PRESSURE SWITCH	エアプレッシャースイッチ	(1)
6		PJ-3090052-03	QUICK JOINT PLUG	クイックジョイントプラグ	(1)
7		G5430-116-000	AIR COCK	エアコック	(1)
8		PF-0552040-B0	FILTER REGULATOR	フィルタレギュレータ	(1)
9		PJ-0305200-01	RING JOINT (NIPPLE)	カンツキテ (ニップル)	(2)
10		PJ-3050652-02	TEE	リョウグチテイ	(1)
11		HK-0346100-40	HOUSING	ハウジング	(1)
12		EA-9500B01-00	CABLE BAND	ソクセンバンド	(5)
13		PX-9500090-00	PLUG	プラグ	(1)
14		HK-0346400-00	PIN CONTACT	ピンターミナル	(3)
15		B8211-206-000	FILTER INSTALLING PLATE	フィルタトリツケイタ	1
16		BT-0600401-EB	TUBE	チューブ	1
17		SL-4051091-SC	SCREW M5X0.8 L=10	ナットネジ M5X0.8 L=10	2
18		SL-9082093-SE	SCREW	ナットネジ	1
19		WP-0871602-SE	WASHER 8.7X18X1.6	ワッシャー 8.7X18X1.6	1
20		NM-6080721-SE	NUT M8	ロツカクナツト M8	1
21		SL-4042081-SC	SCREW	ナットネジ	2

15. LUBRICATION COMPONENTS

給油関係

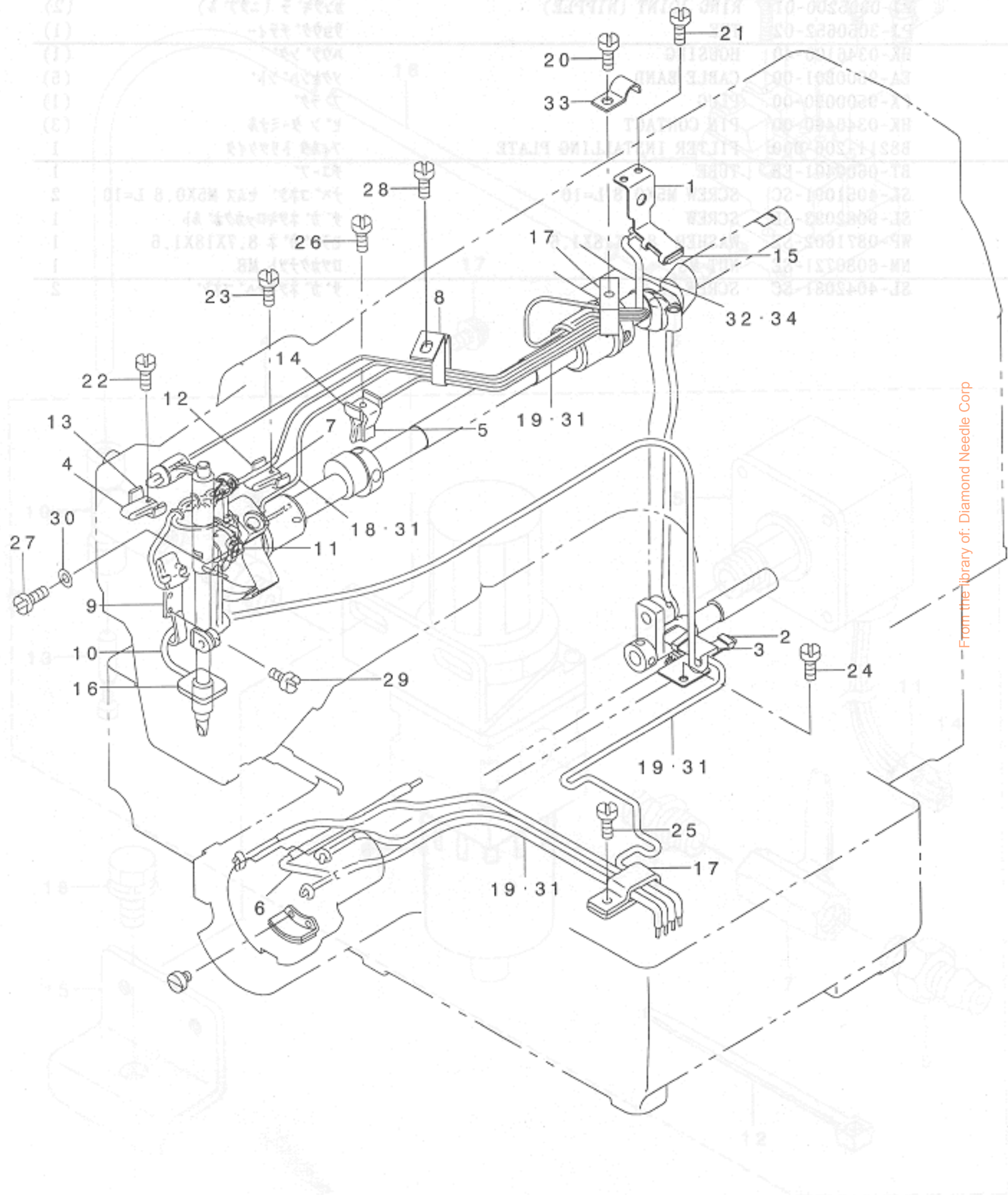

From the library of: Diamond Needle Corp

REF. NO	NOTE	PART NO.	DESCRIPTION	ヒョウメ	Qty
1		B3505-210-D00	CRANK ROD LUBRICATION PLATE	クランクロッド キュウコハシ	1
2		B3506-210-D00	LUBRICATION PLATE	シモシキョウコハシ	1
3		B3509-210-D00	OIL FELT	シモシキョウコハシ	1
4		B3518-210-000	OIL SPONGE	デンビシキョウコハシ	1
5		B3520-220-000	OIL SPONGE	ナカオサエ キョウコハシ	1
6		B3522-210-0A0	OIL FELT ASM.	オオカ マカンリユウフェルト クミ	1
7		B3518-210-000	OIL SPONGE	デンビシキョウコハシ	1
8		B3508-220-000	OIL TUBE HOLDER	ビニールパイプ オサエ	1
9		B3502-220-0A0	NEEDLE ROD CRANK OIL WICK COMP	ハリボウ クランク ユツン クツコウ	1
10		B3523-220-000	OIL FELT	カンリユウ フェルト	1
11		B3507-220-000	OIL WICK HOLDER	ハリボウ ユツンオサエ	1
12		B3508-280-000	BALANCE LUBRICATING PLATE	デンビシキョウコハシ	1
13		B3508-280-000	BALANCE LUBRICATING PLATE	デンビシキョウコハシ	1
14		B3508-280-000	BALANCE LUBRICATING PLATE	デンビシキョウコハシ	1
15		B3509-280-000	NEEDLE ROD CRANK LUBRICATING	ハリボウ クランク キョウコハシ	1
16		B3507-280-000	OIL FELT	メンブ フェルト	1
17		D2112-555-B00	CORD HOLDER, LARGE	コート トメカナク A	2
18		CQ-2020000-00	OIL WICK	ユツン	1
19		CQ-2522000-00	OIL WICK	ユツン	2.5
20		SS-4120915-SP	SCREW 3/16-28 L=9	ナハネジ 3/16-28 L=9	1
21		SS-4120615-SP	SCREW 3/16-28 L=6	ナハネジ 3/16-28 L=6	2
22		SS-6092120-SP	SCREW 9/64-40 L=21.2	ヒラネジ 9/64-40 L=21.2	1
23		SS-6092120-SP	SCREW 9/64-40 L=21.2	ヒラネジ 9/64-40 L=21.2	1
24		SS-6111140-SP	SCREW 11/64-40 L=11	ヒラネジ 11/64-40 L=11	2
25		SS-7110840-SP	SCREW 11/64-40 L=7.8	マルヒラネジ 11/64-40 L=7.8	1
26		SS-6092120-SP	SCREW 9/64-40 L=21.2	ヒラネジ 9/64-40 L=21.2	1
27		SS-4110715-SP	SCREW 11/64-40 L=7	ナハネジ 11/64-40 L=7	1
28		SS-4120615-SP	SCREW 3/16-28 L=6	ナハネジ 3/16-28 L=6	1
29		SS-7110710-SP	SCREW 11/64-40 L=7	マルヒラネジ 11/64-40 L=7	1
30		WP-0450000-SD	WASHER 4.5X8X0.5	ヒラサガネ 4.5X8X0.5	1
31		BP-3000000-00	VINYL PIPE	ビニールパイプ	3.5
32		BP-6000000-00	VINYL PIPE	ビニールパイプ	0.6
33		D2611-555-B00-A	CABLE HOLDER	ケーブル トメカナク	1
34		B3523-220-000	OIL FELT	カンリユウ フェルト	1

16. TABLE COMPONENTS

脚卓関係

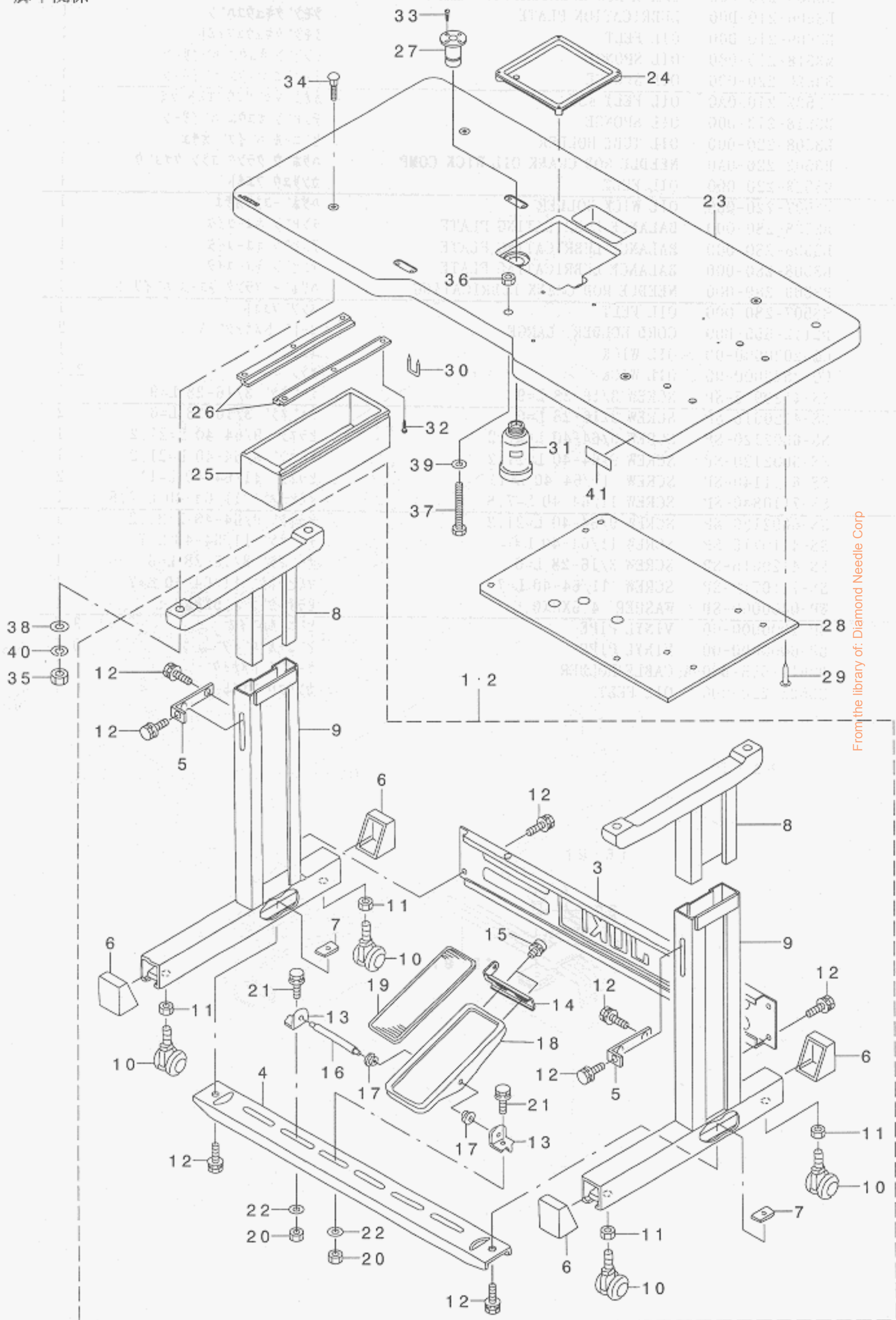

From the library of: Diamond Needle Corp

REF. NO	NOTE	PART NO.	DESCRIPTION	品名	Qty
1	#01	B8101-210-DA0	T-STAND ASM. (MAGNET TYPE)	Tキヤクケツゴウウ(テ'ン'シ'キ)	1
2	#02	B8101-210-DAA	T-STAND ASM. (PNEUMATIC TYPE)	Tキヤクケツゴウウ(エア-シ'キ)	1
3		111-58300	STAND SIDE SUPPORT	ヨコ シチュウ	(1)
4		111-58409	STAND SIDE SUPPORT	シタ シチュウ	(1)
5		111-58516	UPPER STAND PLATE	ウワキヤクトメイタ	(2)
6		111-58607	RUBBER CAP	キヤクト'タ'イ キヤツブ	(4)
7		170-07402	NUT	44カクナツト	(2)
8		B8101-210-AAB	UPPER STAND ASM.	ウエキヤクケツゴウウ	(2)
9		B8105-210-AAA	STAND ASM.	シチュウケツゴウウ	(2)
10		B8150-210-000	CASTER	テ-フ'ルキヤスタ	(4)
11		NM-6120003-SE	NUT M12	ロツカクナツト M12 3シユ	(4)
12		SL-9082093-SE	SCREW	サ'カ'ネツキロツカクホ'ルト	(12)
13	#01	111-59001	PEDAL SHAFT BRACKET	フミタ シ'クウケ	(2)
14	#01	GPF-06080000	PEDAL ADJUSTING PLATE	フミタ チョウセツハ'ン	(1)
15	#01	SL-9061293-SE	WASHER HEXAGONAL BOLT	サ'カ'ネツキロツカクホ'ルト	(2)
16	#01	B8153-771-000	PEDAL CONNECTING ROD	ハ'タ'ルシ'ク	(1)
17	#01	D8113-555-B00	PEDAL BUSHING	フミタ フ'ツシユ	(2)
18	#01	GPF-06060000	PEDAL	ハ'タ'ル	(1)
19	#01	GPF-06070000	PEDAL MAT	ハ'タ'ル マット	(1)
20	#01	NM-6080721-SE	NUT M8	ロツカクナツト M8	(2)
21	#01	SL-9082093-SE	SCREW	サ'カ'ネツキロツカクホ'ルト	(2)
22	#01	WP-0871602-SE	WASHER 8.7X18X1.6	ヒラサ'カ'ネ 8.7X18X1.6	(2)
23		B8201-210-D00	TABLE	テ-フ'ル	1
24		B8110-210-D00	OIL RESERVOIR	オイルハ'ン	1
25		111-55108	DRAWER	ヒキタ'シ	1
26		111-55207	DRAWER SUPPORT	ヒキタ'シ ササエ	2
27		B8202-205-000	OIL MANAGEMENT	ア'フ'ラスキ	1
28		B8203-205-000-A	TABLE EARTH PLATE	テ-フ'ルア-ズイタ	1
29		B8210-012-000	CUSHION SET NAIL	クキ' (20ミリ)	2
30		D8204-555-D00	DRAWER STOPPER	ヒキタ'シ ストツハ'-	1
31		B9121-012-000	OIL CAN	ア'フ'ラヒ'ン	1
32		SK-3311600-SC	WOOD SCREW D=3.1 L=16	マルモクネジ' D=3.1 L=16	6
33		SK-3311600-SC	WOOD SCREW D=3.1 L=16	マルモクネジ' D=3.1 L=16	2
34		MAO-11108N00	PEDAL SWITCH FRAME BOLT	テコ トリツクタ'イ ホ'ルト	4
35		NM-6060001-SC	NUT M6	ロツカクナツト M6 1シユ	4
36		NM-6080001-SC	NUT M8X1.25	ロツカクナツト M8 1シユ	1
37		SM-9086523-SE	HEXAGONAL BOLT	ロツカクホ'ルト	1
38		WP-0641601-SC	WASHER	ヒラサ'カ'ネ ミカ'キマル M6	4
39		WP-0851846-SC	WASHER 8.5X22.0X1.8	ヒラサ'カ'ネ 8.5X22X1.8	1
40		WS-0610002-KN	SPRING WASHER 6.1X12.2X1.5	ハ'ネサ'カ'ネ M6	4
41	(1) #03	CM-5001000-01	CE MARKING LABEL	CEマ-キング' メイハ'ン(JUKIシヨウ)	1
42	(2)				(1)
43	(1)	NOTE (注記)	#01... FOR 210DSS, DHS	210DSS, DHS用	(2)
44	(1)		#02... FOR 210DSL, DHL	210DSL, DHL用	(1)
45	(1)		#03... FOR JE	JE用	(1)
46	(2)				(1)
47	(1)				1
48	(2)				2
49	(2)				(2)
50	(1)				(1)
51	(2)				(2)
52	(1)				(1)
53	(2)				(2)

From the library of: Diamond Needle Corp

17. THREAD STAND COMPONENTS

糸立て装置関係

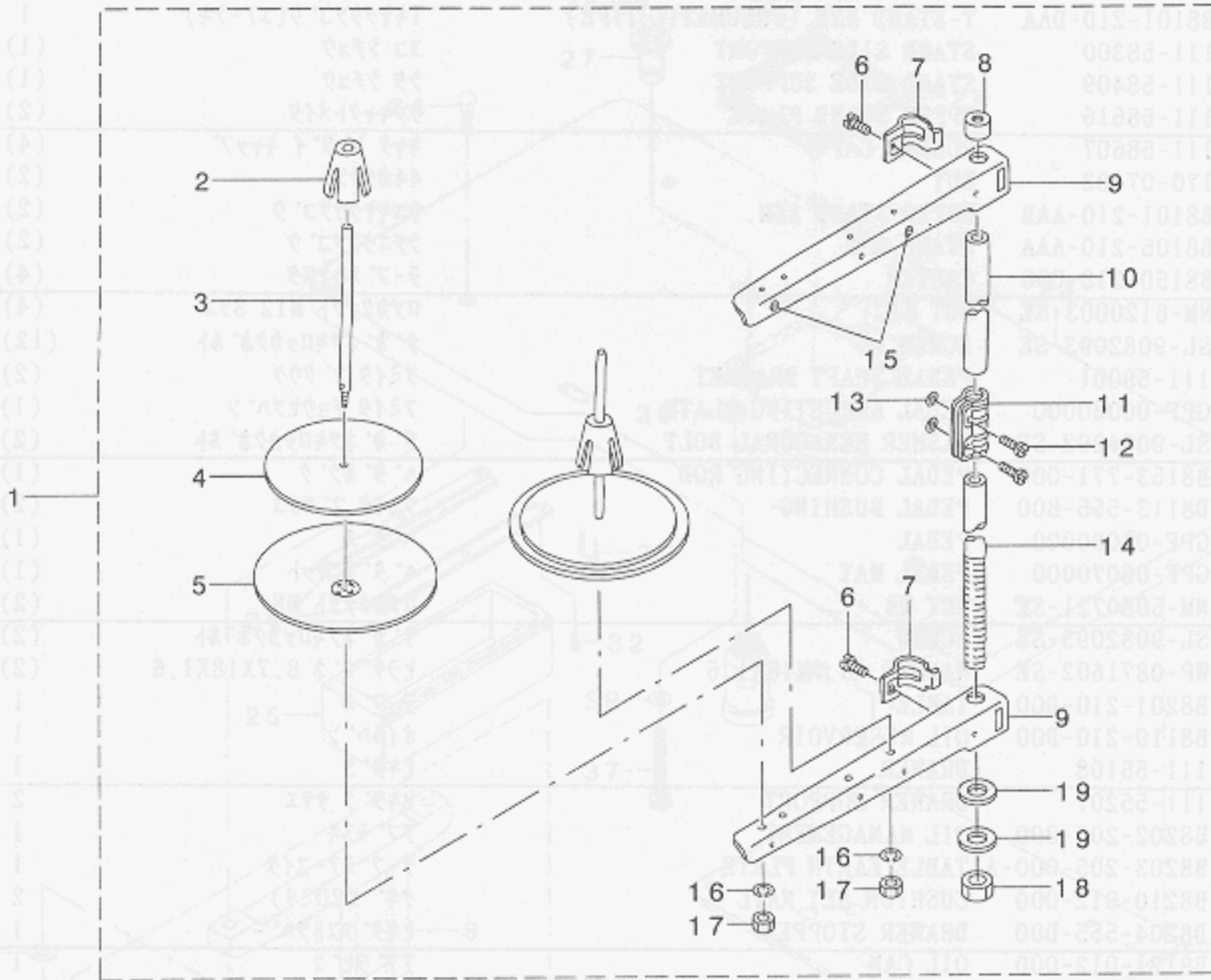

REF. NO	NOTE	PART NO.	DESCRIPTION	ヒョウメイ	Qty
1		229-30358	THREAD STAND ASM.	糸立てソウチ(クミ)	1
2		229-31109	SPOOL RETAINER	糸マキプレート	(2)
3		229-31000	SPOOL PIN	糸マキウケホウ	(2)
4		229-30903	SPOOL REST CUSHION	糸マキウケサ ラククッション	(2)
5		229-30804	SPOOL REST	糸マキウケサ ラ	(2)
6		SM-6061610-SC	SCREW M6 L=16	ヒラコネジ M6 L=16	(2)
7		229-30705	THREAD GUIDE ARM JOINT	糸タテホ ウツメカナク	(2)
8		229-31406	SPOOL REST ROD RUBBER CAP	糸タテホ ウホコ ゴム	(1)
9		229-30507	SPOOL REST ARM	糸タテウデ	(2)
10		229-30408	SPOOL REST ROD, UPPER	糸タテホ ウ(ウエ)	(1)
11		229-31307	SPOOL REST ROD JOINT	糸タテホ ウツキテ	(1)
12		SM-4051405-SE	SCREW M5 L=14	ナハコネジ M5 L=14	(2)
13		NM-6050001-SE	NUT M5	ロツカクナツト M5	(2)
14		229-30309	SPOOL REST ROD, LOWER	糸タテホ ウ(シタ)	(1)
15		229-31208	THREAD GUIDE	糸ミチ	(2)
16		WS-0510002-KN	SPRING WASHER	ハネサカネ 5.1X9.2X1.3	(2)
17		NM-6050001-SE	NUT M5	ロツカクナツト M5	(2)
18		NM-6160511-SE	NUT M16X1.5	ロツカクナツト M16X1.5 13ユ	(1)
19		WP-1702600-S0	WASHER 17X30X2.6	ヒラサカネ 17X30X2.6	(2)

From the library of: Diamond Needle Corp

18. OPERATION BOX COMPONENTS

操作ボックス関係

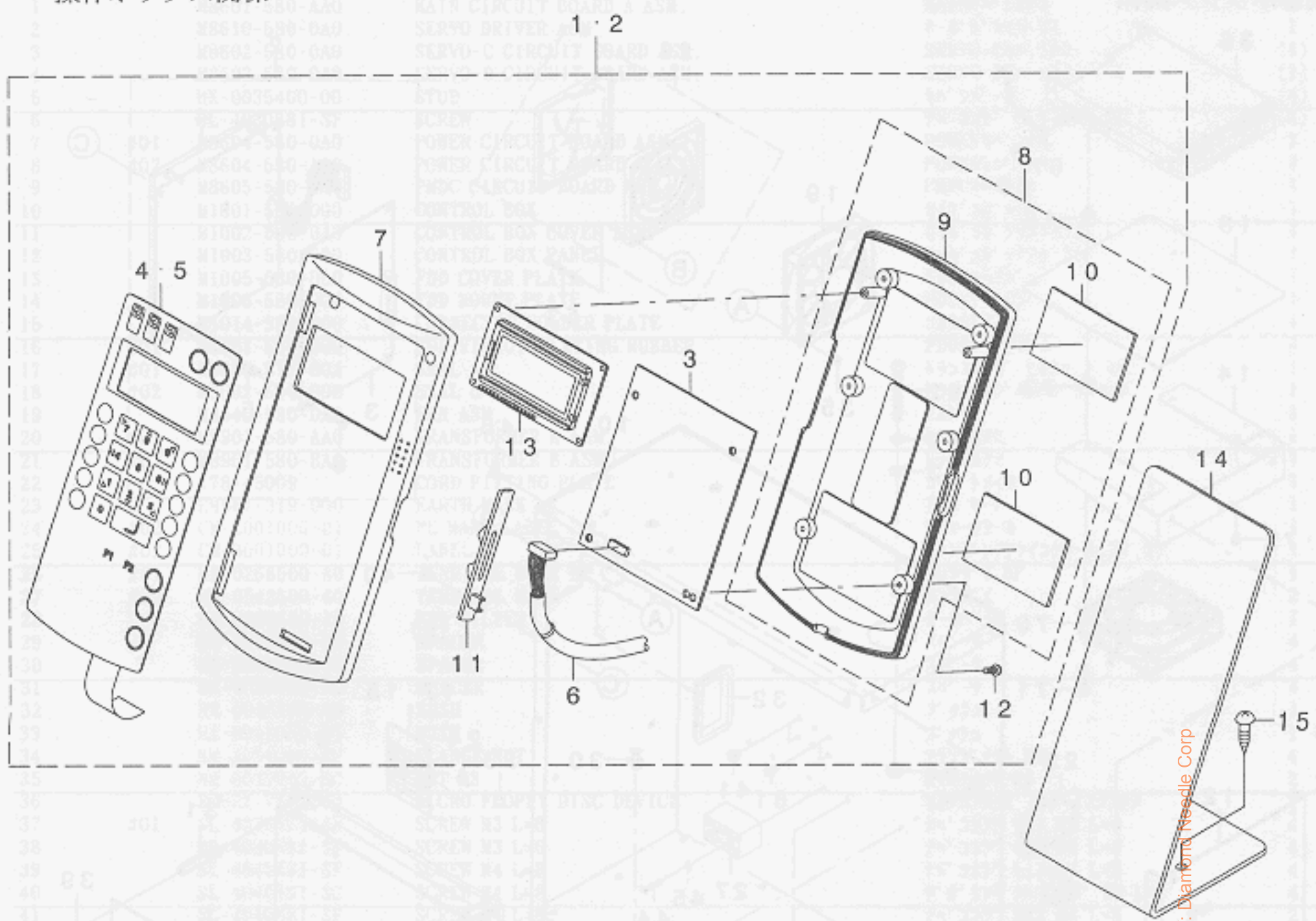

REF. NO	NOTE	PART NO.	DESCRIPTION	ヒョウメイ	Qty
1	#01	M8510-580-AA0	OPERATION BOX J ASM.	ソウサハ* コJクミ	1
2	#02	M8510-580-BA0	OPERATION BOX E ASM.	ソウサハ* コEクミ	1
3		M8606-580-0A0	OPERATION CIRCUIT BOARD ASM.	ソウサキハ* シクミ	(1)
4	#01	M3005-580-00A	OPERATION PANEL SHEET(JAPAN)	ソウサハ* ネルシート(サブ* シ)	(1)
5	#02	M3005-580-00B	OPERATION PANEL SHEET(ENGLISH)	ソウサハ* ネルシート(エイブ* シ)	(1)
6		M9012-580-0A0	PANEL SIGNAL CORD ASM.	ハ* ネルシゴ* ウコート* クミ	(1)
7		M1030-580-000	OPERATION BOX UPPER CASE	ソウサハ* ックスウエケース	(1)
8		M1031-580-0A0	OPERATION BOX LOWER CASE ASM.	ソウサハ* ックスシタケースクミ	(1)
9		M1031-580-000	OPERATION BOX LOWER CASE	ソウサハ* ックスシタケース	(1)
10		M1011-580-000	MAGNET SHEET	マグ* ネットシート	(2)
11		M1032-580-000	VOLUME TONGUE	ホ* リュームツマミ	(1)
12		ST-4031051-SN	TAPPING SCREW D=3-24 L=10	タツビ* シネツ* D=3-24 L=10	(6)
13		M8541-580-0A0	LCD ASM.	エキシヨウヒヨウツ* キクミ	(1)
14		M1017-580-000	OPERATION BOX INSTALLING PLATE	ソウサハ* コトリツケイタ	1
15		SK-3451600-SC	WOOD SCREW D=4.5 L=16	マルモクネツ* D=4.5 L=16	2

NOTE (注記) #01...FOR DOMESTIC USE 国内用
 #02...FOR EXPORT 輸出用

From the library of: Diamond Needle Corp

19. CONTROL BOX COMPONENTS

制御ボックス関係

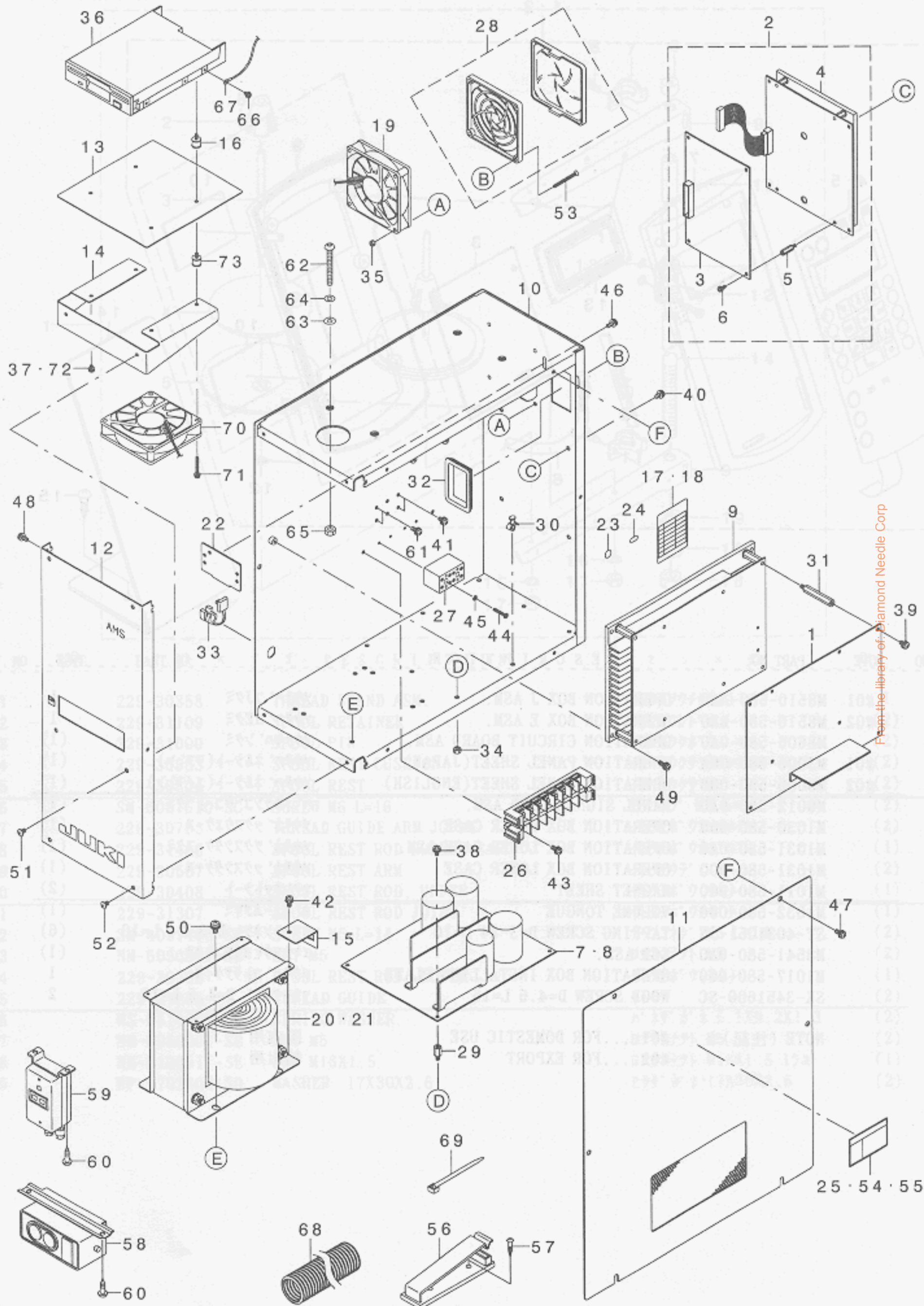

From the library of: Diamond Needle Corp

REF. NO	NOTE	PART NO.	DESCRIPTION	品名	Qty
1		M8601-580-AA0	MAIN CIRCUIT BOARD A ASM.	MAINキハ'ソクミ	1
2		M8610-580-OA0	SERVO DRIVER ASM.	サーボ'ト'ライハ'クミ	1
3		M8602-580-OA0	SERVO-C CIRCUIT BOARD ASM.	SERVO-Cキハ'ソクミ	(1)
4		M8603-580-OA0	SERVO-D CIRCUIT BOARD ASM.	SERVO-Dキハ'ソクミ	(1)
5		HX-0035400-00	STUD	キハ'ソハ'-ツ	(4)
6		SL-4030881-SF	SCREW	ナハ'コネジ' セムス M3 L=8	(4)
7	#01	M8604-580-OA0	POWER CIRCUIT BOARD ASM.	POWERキハ'ソクミ	1
8	#02	M8604-580-AA0	POWER CIRCUIT BOARD A ASM.	POWERキハ'ソクミ	1
9		M8605-580-OA0	PMDC CIRCUIT BOARD ASM.	PMDCキハ'ソクミ	1
10	#03	M1001-580-000	CONTROL BOX	セイキ'ヨホ'ボックス	1
11	#04	M1002-580-OA0	CONTROL BOX COVER ASM.	セイキ'ヨホ'ボックスフタクミ	1
12		M1003-580-000	CONTROL BOX PANEL	セイキ'ヨホ'ボックスハ'ネ	1
13	#05	M1005-580-000	FDD COVER PLATE	FDDシャハ'イハ'ソ	1
14		M1006-580-000	FDD MOUNT PLATE	FDDトリツケイタ	1
15		M1014-580-000	CONNECTOR HOLDER PLATE	コネクタ'ホ'メイタ	1
16	#01	M2001-580-000	FDD VIBROISOLATING RUBBER	FDDホ'ウランゴ'ム	4
17	#01	M3005-511-00A	SEAL A	トランス'スタ'ップ' ヒヨウジ' シ-ルA	1
18	#02	M3002-580-00B	SEAL B	トランス'スタ'ップ' ヒヨウジ' シ-ルB	1
19		M8540-580-OA0	FAN ASM.	FANクミ	1
20	#01	M8901-580-AA0	TRANSFORMER A ASM.	トランスAクミ	1
21	#02	M8901-580-BA0	TRANSFORMER B ASM.	トランスBクミ	1
22		178-45009	CORD FITTING PLATE	コード'ト'メイタ	1
23		E9567-319-000	EARTH MARK	ア-ス マ-ク	1
24	#02	CM-2001000-01	PE MARK LABEL	PEマ-クシ-ル	1
25	#02	CM-3001000-01	LABEL	キケン'テ'ソ'ア'ツケイコクシ-ル(31.5)	1
26	#01	HK-0266500-80	TERMINAL BASE 8P	タンジ'ダ'イ 8P	1
27	#02	HK-0542500-40	TERMINAL BASE	タンジ'ダ'イ	2
28		HM-0008600-10	FAN FILTER	モ-タハ'-ツ	1
29		HX-0005600-0B	SPACER	スハ'-サ	4
30		HX-0014700-0C	SPACER	スハ'-サ	4
31		HX-0033900-0D	SPACER	スハ'-サ	4
32		HX-0040700-00	BUSH	ブ'ツシュ	1
33		HX-0041000-00	BUSH	ブ'ツシュ	1
34		NM-3034000-SF	FLANGE NUT	フランジ'ナ'ツト M3	4
35		NM-6030003-SC	NUT M3	ロツカク'ナ'ツト M3	2
36		S9622-710-000	MICRO FLOPPY DISC DEVICE	マイクロ'フロッピー'イ-デ'イス'クワ'ウチ	1
37	#01	SL-4030681-SF	SCREW M3 L=6	ナハ'コネジ' セムス M3 L=6	4
38		SL-4030681-SF	SCREW M3 L=6	ナハ'コネジ' セムス M3 L=6	4
39		SL-4040881-SF	SCREW M4 L=8	ナハ'コネジ' セムス M4 L=8	4
40		SL-4040891-SC	SCREW M4 L=8	サ'カ'ネツキ'ナハ'コネジ' M4 L=8	4
41		SL-4040881-SF	SCREW M4 L=8	ナハ'コネジ' セムス M4 L=8	2
42		SL-4041081-SF	SCREW M4 L=10	ナハ'コネジ' セムス M4 L=10	1
43	#01	SL-4041081-SF	SCREW M4 L=10	ナハ'コネジ' セムス M4 L=10	2
44	#02	SM-4031851-SR	SCREW	ナハ'コネジ' M3 L=18	4
45	#02	WS-0310702-KS	SPRING WASHER	ハ'ネサ'カ'ネ 3.1X5.9X0.7	4
46		SL-4041091-SC	SCREW M4 L=10	ナハ'コネジ' セムス M4X0.7 L=10	2
47		SL-4041091-SC	SCREW M4 L=10	ナハ'コネジ' セムス M4X0.7 L=10	6
48		SL-4041091-SC	SCREW M4 L=10	ナハ'コネジ' セムス M4X0.7 L=10	3
49		SL-4041281-SF	SCREW M4 L=12	ナハ'ネジ' M4X0.7 L=12 セムス	4
50		SL-4051081-SF	SCREW M5 L=10	サ'カ'ネツキ'ネジ'	4
51		SM-0040601-SC	SCREW M4X0.7 L=6	トラス'コネジ' M4X0.7 L=6	2
52		SM-0040601-SC	SCREW M4X0.7 L=6	トラス'コネジ' M4X0.7 L=6	4
53		SM-1033501-SC	SCREW M3X0.5 L=35	チラ'コネジ' M3X0.5 L=35	2
54	#03	CM-3001001-01	DANGER LABEL (SMALL)	デ'ンゲ'キケン'シ-ル'ル(シヨウ)	1
55	#04	G6705-152-UOA	LABEL	イナ'ズ'マ-ク	1
56		M9640-510-00A	CABLE CLIP	ケー'ブ'ル'クリッ'プ	2
57		SK-3382001-SE	SCREW D=3.8 L=20	マル'モク'ネジ' D=3.8 L=20	4
58	#01	HA-0042500-00	SWITCH	スイ'ッチ	1
59	#02	HA-0030300-OA	SWITCH	スイ'ッチ	1
60		SK-3512001-SF	WOOD SCREW	マル'モク'ネジ' D=5.1 L=20	2
61		SL-4041091-SC	SCREW M4 L=10	ナハ'コネジ' セムス M4X0.7 L=10	2
62		SM-3065052-TC	SCREW	マル'ネジ' M6 L=50	4
63		WP-0651001-SC	WASHER	ヒラ'サ'カ'ネ	4
64		WS-0610002-KN	SPRING WASHER 6.1X12.2X1.5	ハ'ネサ'カ'ネ M6	4
65		NM-6060001-SC	NUT M6	ロツカク'ナ'ツト M6 1ツ	4
66		SL-4030681-SF	SCREW M3 L=6	ナハ'コネジ' セムス M3 L=6	1
67		M9029-580-OA0	FDD EARTH CORD ASM.	FDDア-ス'センクミ	1
68		HX-0030700-00	TUBE	チュ-ブ	0.3
69		EA-9500B02-00	CABLE BAND 150	ケツ'クハ'ソ'ト' 150	5
70	#02	M8540-580-AA0	FAN ASM. ,A	ファン(A)クミ	1
71	#02	SL-4032591-SC	SCREW M3X25	ナハ'コネジ' セムス M3X0.5 L=25	2
72	#02	SL-4030681-SF	SCREW M3 L=6	ナハ'コネジ' セムス M3 L=6	2
73	#02	M2001-580-000	FDD VIBROISOLATING RUBBER	FDDホ'ウランゴ'ム	4

NOTE (注記)

#01...FOR 100~200V
 #02...FOR 380V
 #03...FOR 100~200V(DOMESTIC USE)
 #04...FOR 100~200V(EXPORT)

100~200V用
 380V用
 100~200V用(国内用)
 100~200V用(輸出用)

20. WIRING DIAGRAM

電装配線図

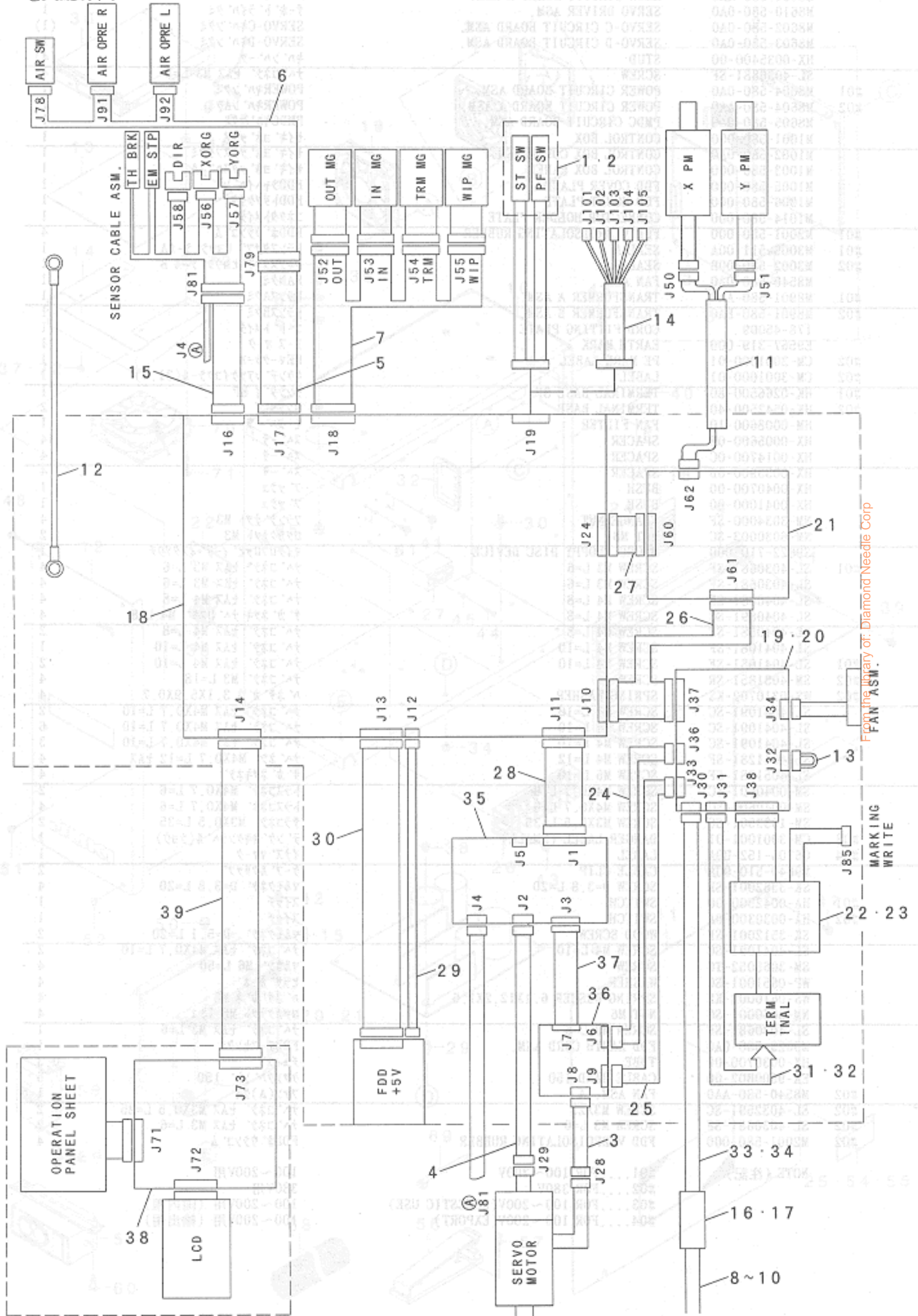

From the library of: Diamond Needle Corp
FAN ASM.

MARKING
WRITE

REF. NO	NOTE	PART NO.	DESCRIPTION	ヒョウメイ	Qty
1	#01	M8520-580-0A0	2-PEDAL ASM.	2レンパ タ ルクミ	1
2	#01	M8521-580-0A0	3-PEDAL ASM.	3レンパ タ ルクミ	1
3		M9003-580-0A0	SERVO MOTOR CABLE ASM.	SERVOモータケブ ルクミ	1
4		M9004-580-0A0	ENCODER CONNECTING CABLE ASM.	エンコダ チュウケイケブ ルクミ	1
5	#02	M9014-580-0A0	SOLENOID CONNECTING CABLE ASM.	デソノイ ドン チュウケイケブ ルクミ	1
6	#02	M9015-580-0A0	SOLENOID VALVE CABLE ASM.	デソノイ ドン ケブ ルクミ	1
7		M9016-580-0A0	SOLENOID CABLE ASM.	ソレノイ ト ケブ ルクミ	1
8	#03	M9017-580-0A0	POWER CABLE ASM.	デソノイ ト ケブ ルクミ	1
9	#04	M9024-580-0A0	POWER CABLE ASM., 100V	デソノイ ト ケブ ル 100Vヨウクミ	1
10	#05	M9028-580-0A0	POWER CABLE ASM.	デソノイ ト ケブ ルクミ	1
11		M9018-580-0A0	PULSE MOTOR CABLE ASM.	パ ルスモータケブ ルクミ	1
12		M9019-580-0A0	EARTH CABLE ASM.	トウブ アースケブ ルクミ	1
13	#04	M9021-580-0A0	VOLTAGE TRANSFER CORD ASM.	デソノイ ト ケブ ルクミ	1
14	#06	M9025-580-0A0	PEDAL SW. TRANSFER CABLE ASM.	パ タ ルスイッチ ハンカケブ ルクミ	1
15		M9026-580-0A0	SENSOR CONNECTING CABLE ASM.	トウブ センサ チュウケイケブ ルクミ	1
16	#07	HA-0042500-00	SWITCH	スイッチ	1
17	#05	HA-0030300-0A	SWITCH	スイッチ	1
18		M8601-580-AA0	MAIN CIRCUIT BOARD A ASM.	MAINキハ ンクミ	1
19	#07	M8604-580-0A0	POWER CIRCUIT BOARD ASM.	POWERキハ ンクミ	1
20	#05	M8604-580-AA0	POWER CIRCUIT BOARD A ASM.	POWERキハ ンクミ	1
21		M8605-580-0A0	PMDC CIRCUIT BOARD ASM.	PMDCキハ ンクミ	1
22	#07	M8901-580-AA0	TRANSFORMER A ASM.	トランスAクミ	1
23	#05	M8901-580-BA0	TRANSFORMER B ASM.	トランスBクミ	1
24		M9001-580-0A0	SERVO POWER CORD ASM., A	SERVOデソノイ ト ケブ ルクミ	1
25		M9002-580-0A0	SERVO POWER CORD ASM., B	SERVOデソノイ ト ケブ ルクミ	1
26		M9005-580-0A0	MP POWER CORD ASM.	MPデソノイ ト ケブ ルクミ	1
27		M9007-580-0A0	PMDC SIGNAL CORD ASM.	PMDCシグナル ケブ ルクミ	1
28		M9008-580-0A0	SERVO SIGNAL CORD ASM.	SERVOシグナル ケブ ルクミ	1
29		M9009-580-0A0	FDD POWER CORD ASM.	FDD デソノイ ト ケブ ルクミ	1
30		M9010-580-0A0	FDD SIGNAL CORD ASM.	FDD シグナル ケブ ルクミ	1
31	#07	M9020-580-0A0	TRANSFORMER POWER CORD ASM.	トランスデソノイ ト ケブ ルクミ	1
32	#05	M9020-580-AA0	TRANSFORMER POWER CORD ASM., A	トランスデソノイ ト ケブ ルクミ	1
33	#07	M9022-580-0A0	POWER CORD ASM.	デソノイ ト ケブ ルクミ	1
34	#05	M9027-580-0A0	POWER CORD ASM.	デソノイ ト ケブ ルクミ	1
35		M8602-580-0A0	SERVO-C CIRCUIT BOARD ASM.	SERVO-Cキハ ンクミ	1
36		M8603-580-0A0	SERVO-D CIRCUIT BOARD ASM.	SERVO-Dキハ ンクミ	1
37		M9023-580-0A0	SERVO CONNECTING CORD ASM.	SERVOセツブ ケブ ルクミ	1
38		M8606-580-0A0	OPERATION CIRCUIT BOARD ASM.	ソウサキハ ンクミ	1
39		M9012-580-0A0	PANEL SIGNAL CORD ASM.	パ ネルシグナル ケブ ルクミ	1

NOTE (注記)

- #01...SELECTIVE PART
- #02...FOR 210DSL, DHL
- #03...FOR 200V
- #04...FOR 100V
- #05...FOR 380V
- #06...FOR OPTION
- #07...FOR 100~200V

- 選択部品
- 210DSL, DHL用
- 200V用
- 100V用
- 380V用
- オプション部品
- 100~200V用

From the library of: Diamond Needle Corp

21. PEDAL & ELECTRICAL EQUIPMENT ACCESSORIE PART COMPONENTS

ペダル・電装付属品関係

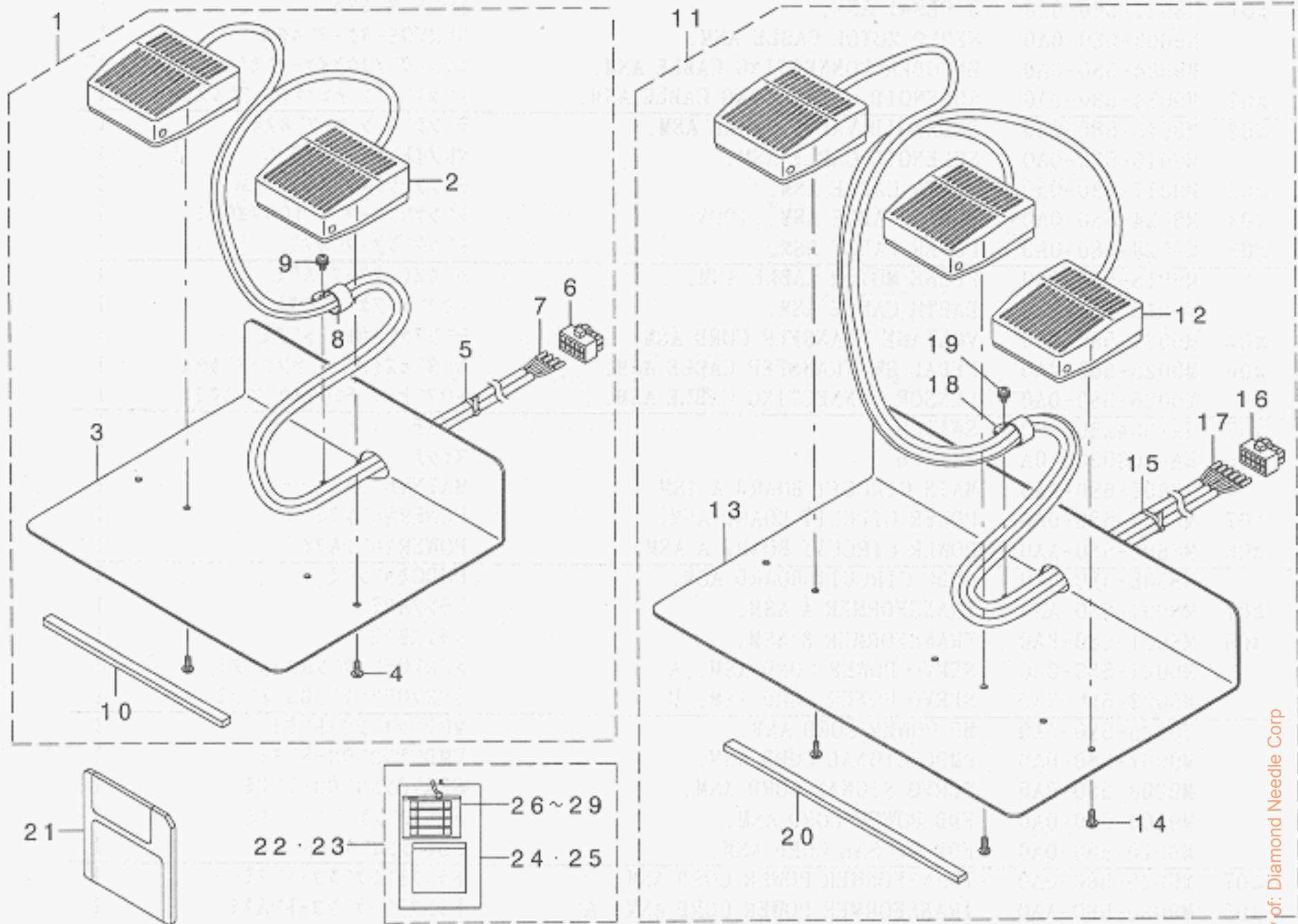

REF. NO	NOTE	PART NO.	DESCRIPTION	ヒョウメイ	Qty
1	#01	M8520-580-0A0	2-PEDAL ASM.	2ペダル タルグミ	1
2		HA-0042600-00	FOOT SWITCH	フットスイッチ	(2)
3		M1012-580-000	SW. MOUNT PLATE A	SWトリツクイタ A	(1)
4		ST-5041051-SN	SCREW	タダビソネジ	(4)
5		EA-9500B01-00	CABLE BAND	ソクセンバソト	(4)
6		HK-0346101-00	TOP CONNECTOR	ハクダソク TOP	(1)
7		HK-0346400-00	PIN CONTACT	ピンタミナル	(4)
8		EA-9502B05-00	CABLE CLIP	ケアソクリツア	(1)
9		SL-4040881-SF	SCREW M4 L=8	ナハコネジ 4x8 M4 L=8	(1)
10		GPK-26002000	PEDAL BASE RUBBER	ペダル タイコ	(2)
11	#01	M8521-580-0A0	3-PEDAL ASM.	3ペダル タルグミ	1
12		HA-0042600-00	FOOT SWITCH	フットスイッチ	(3)
13		M1016-580-000	SW. MOUNT PLATE, B	SWトリツクイタ B	(1)
14		ST-5041051-SN	SCREW	タダビソネジ	(6)
15		EA-9500B01-00	CABLE BAND	ソクセンバソト	(4)
16		HK-0346101-00	TOP CONNECTOR	ハクダソク TOP	(1)
17		HK-0346400-00	PIN CONTACT	ピンタミナル	(6)
18		EA-9502B05-00	CABLE CLIP	ケアソクリツア	(1)
19		SL-4040881-SF	SCREW M4 L=8	ナハコネジ 4x8 M4 L=8	(1)
20		GPK-26002000	PEDAL BASE RUBBER	ペダル タイコ	(1)
21		M8902-580-000	FLOPPY DISC	フロッピーディスク	1
22	#02	M8599-580-0A0	ACCESSORIE PART ASM.	アソクリツタ	1
23	#03	M8599-580-AA0	ACCESSORIE PART ASM., A	アソクリツタ A	1
24	#02	M3004-511-00A	VOLTAGE INDICATION CARD, A	デンツキヒョウシヤフタ A	(1)
25	#03	M3003-580-000	VOLTAGE INDICATION CARD, B	デンツキヒョウシヤフタ B	(1)
26		E9613-601-000	FUSE 2A	ガラスカクヒユース 2A	(1)
27		E9629-252-000	FUSE 5A	ヒユース 5A	(1)
28		E8523-304-000	FUSE 10A	ガラスカクヒユース	(1)
29		HF-0041050-P0	FUSE	ヒユース	(1)

NOTE (注記)

#01... SELECTIVE PART
 #02... FOR 100~200V
 #03... FOR 380V

選択部品
 100~200V用
 380V用

22. ACCESSORIE PART COMPONENTS

付属品関係

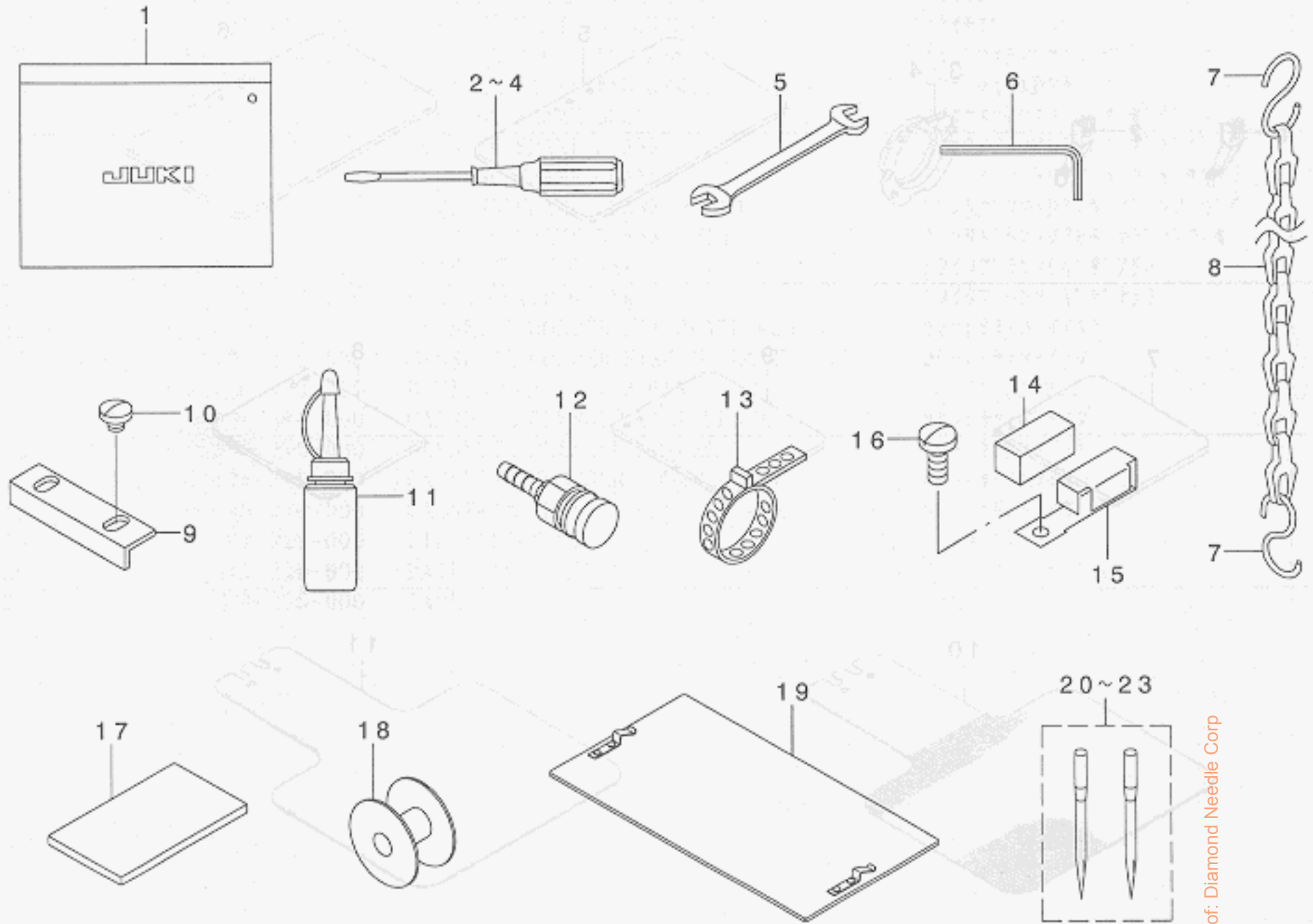

REF. NO	NOTE	PART NO.	DESCRIPTION	キ ャ ッ プ	Qty
1		B9101-552-000	ACCESSORY BOX	アクセサリーボックス	1
2		B9109-555-000	SCREW DRIVER, LARGE	大型ドライバー	1
3		B9110-012-000	SCREW DRIVER, MIDDLE	中型ドライバー	1
4		B9111-012-000	SCREW DRIVER, SMALL	小型ドライバー	1
5		B9113-012-000	WRENCH (9X10)	9X10のレンチ	1
6		B9140-372-000	HEXAGONAL WRENCH, SMALL	小型六角レンチ	1
7	#01	B8133-019-000	S SHAPED HOOK	S字フック	2
8	#01	B8131-019-000	CHAIN	チェーン	1
9	#01	B2592-210-000	PLASTIC PLATE STOPPER	プラスチックプレート止り	1
10	#01	SS-7110340-SP	SCREW 11/64-40 L= 3.2	丸ネジ 11/64-40 L= 3.2	2
11		B9121-220-0A0	OILER (CONTAINING NO.2 OIL)	アブラサシ NO2オイル	1
12	#02	PJ-3095200-01	SOCKET	ハイパーソケット	1
13	#02	PB-0000100-00	HOSE BAND	ホースバンド	1
14		B1131-528-000	FELT	イソソライ イソオキエ	1
15		I01-02259	THREAD GUIDE ASM. F	イソソライ F クミ	1
16		SS-7090910-SP	SCREW 9/64-40 L= 8.5	丸ネジ 9/64-40 L=8.5	1
17		B2564-215-000	SPONGE	スポンジ ソトワケ スポンジ	1
18		B1806-210-D00	BOBBIN	ボビン	1
19	#01	B2557-210-DA0	PLASTIC BLANK PLATE ASM.	プラスチック空白プレートアセンブリ	2
20	#03	MDP-500B1402	NEEDLE DPX5#14-2	DPX5#14-2	1
21	#04	MDP-170B1802	NEEDLE DPZ17#18-2	DPZ17#18-2	1
22	#05	MC-2005010-02	NEEDLE 134 #100-2	134 #100-2	1
23	#06	MC-3720011-02	NEEDLE SY3355 #110-2	SY3355 #110-2	1

NOTE (注記)

#01...	FOR 210DSS, DHS	210DSS, DHS用
#02...	FOR 210DSL, DHL	210DSL, DHL用
#03...	FOR 210DSS, DSL(EXCEPT JE)	210DSS, DSL(JEは除く)
#04...	FOR 210DHS, DHL(EXCEPT JE)	210DHS, DHL(JEは除く)
#05...	FOR 210DSS, DSL(FOR JE)	210DSS, DSL(JE用)
#06...	FOR 210DHS, DHL(FOR JE)	210DHS, DHL(JE用)

23. OPTIONAL PART COMPONENTS

オプション関係

付属品関係

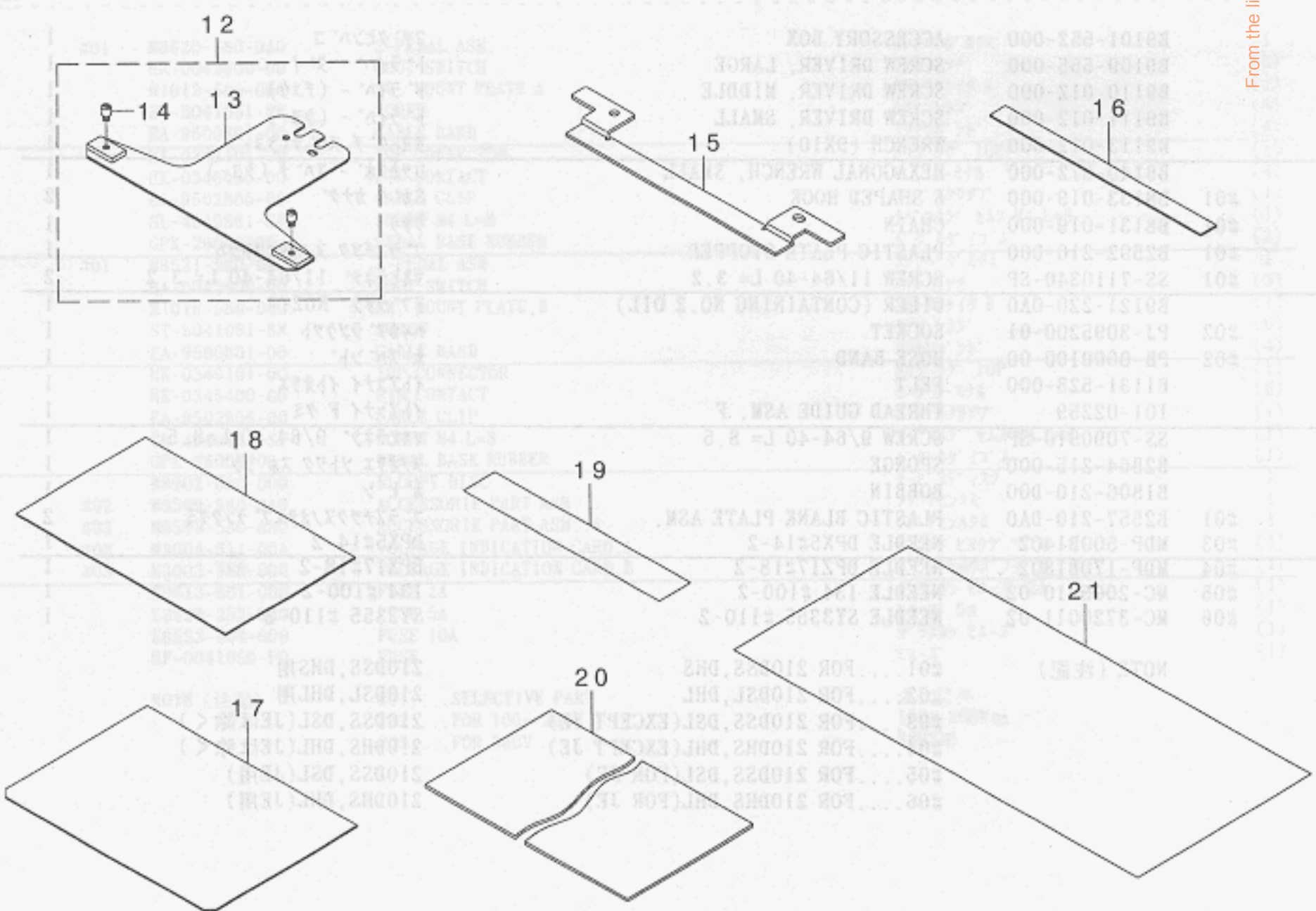
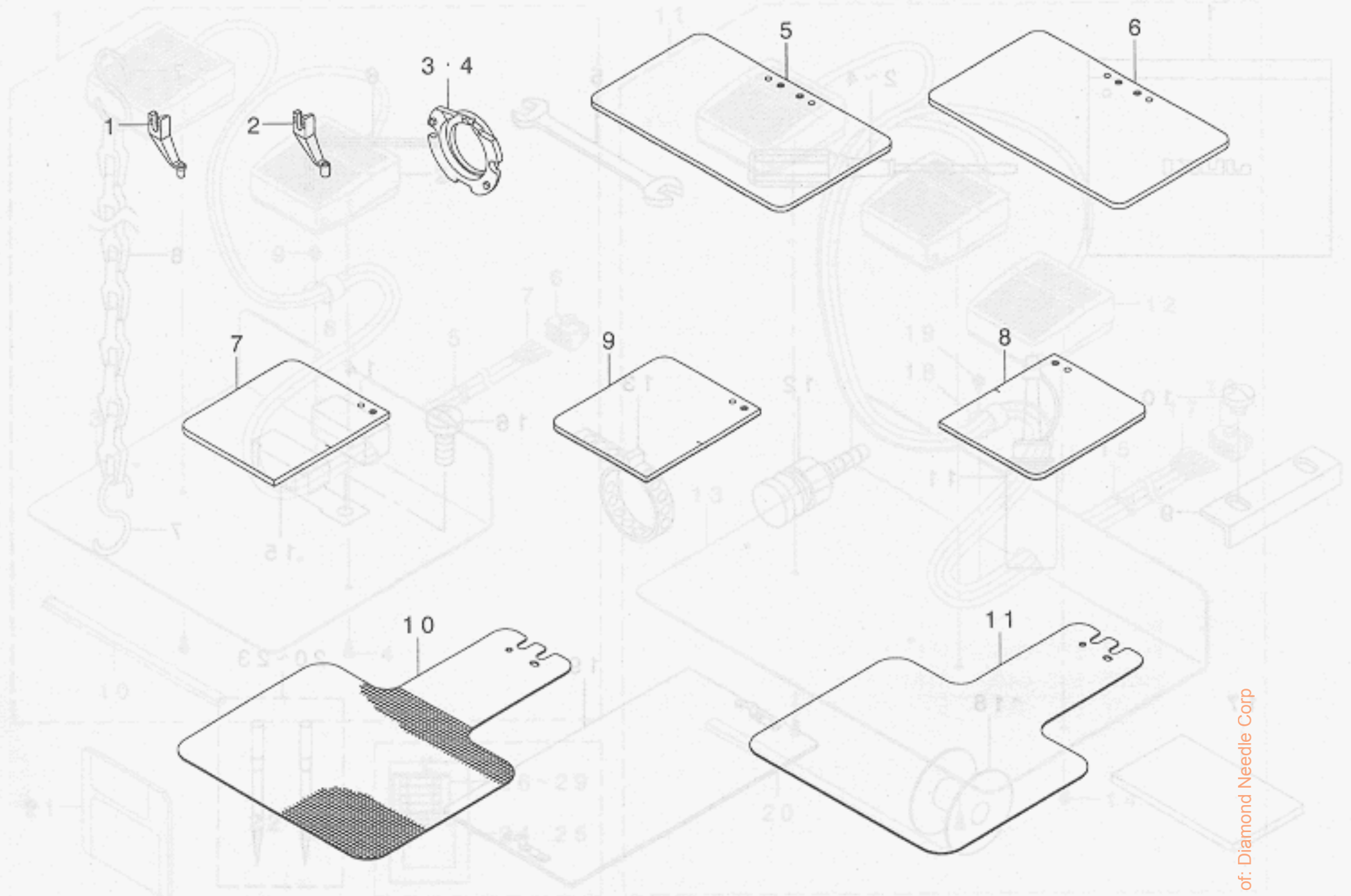

From the library of: Diamond Needle Corp

REF. NO	NOTE	PART NO.	DESCRIPTION	ヒョウメイ	Qty
1		B1601-210-DOB	INTERMEDIATE PRESSER B	ナカオサIB	1
2		B1601-210-DOC	INTERMEDIATE PRESSER C	ナカオサIC	1
3		B1817-210-DAC	SHUTTLE RACE RING ASM., C	ナカガ' マオサECケツコ' ウ	1
4		B1817-210-DAD	SHUTTLE RACE RING ASM., D	ナカガ' マオサEDケツコ' ウ	1
5		B2553-210-DOA	FEEDING FRAME BLANK	ヌノオサエソトワクア' ランク(キ' サ' アリ)	1
6		B2553-210-DOB	FEEDING FRAME BLANK	ヌノオサエソトワクア' ランク(キ' サ' ナシ)	1
7		B2554-210-DOA	FEEDING FRAME BLANK	ブ' ソリカ' タソトワクア' ランク(キ' サ' ナシ)	1
8		B2554-210-DOB	FEEDING FRAME BLANK, RIGHT	ブ' ソリカ' タソトワクミキ' ブ' ランク(キ' サ)	1
9		B2554-210-DOC	FEEDING FRAME BLANK, LEFT	ブ' ソリカ' タソトワクヒタ' リア' ランク(キ'	1
10		B2556-210-DOA	LOWER PLATE BLANK	シタイア' ランク(キ' サ' アリ)	1
11		B2556-210-DOB	LOWER PLATE BLANK	シタイア' ランク(キ' サ' ナシ)	1
12		B2593-210-DA0	CASSETTE HOLDER FIX PLATE ASM.	カセットオサエコテイイタクミ	1
13		B2593-210-D00	CASSETTE HOLDER FIXING PLATE	カセットオサエコテイイタ	(1)
14		B2560-372-000	BUTTON CLAMP STOP PIN	ツマミアシ ヒラキビ' ソ	(2)
15		B2594-210-D00	CASSETTE PRESSER BASE PLATE	カセットオサエタ' イタ	1
16		B2589-210-D00	CASSETTE PRESSER SPACER	カセットオサエスハ' -サ	1
17		B2598-210-D00	CASSETTE PRESSER LOWER PLATE	カセットオサエシタイタ	1
18		B2599-210-D00	CASSETTE PRESSER UPPER PLATE	カセットオサエウエイタ	1
19		B2572-229-000	FILAMENT TAPE	フィラメントテープ	1
20		B2587-210-000	MATERIAL PLATE A	ヌノオサエヨウ ソサ' イ A	1
21		B2646-215-000	TAPE	リヨウメンテープ	1

From the library of: Diamond Needle Corp

NUMERICAL INDEX OF PARTS

索引

PART NO 品番	PAGE 頁	REF NO	PART NO 品番	PAGE 頁	REF NO	PART NO 品番	PAGE 頁	REF NO	PART NO 品番	PAGE 頁	REF NO
A1230-500-000-A	6	17	B1411-804-C00	12	40	B1811-210-DA0	12	19	B2502-210-D00	18	3
A3216-001-00A	2	22	B1411-804-C00	12	44	B1812-210-D00	12	20	B2505-210-D00	18	19
BP-3000000-00	12	15	B1411-804-D00	12	41	B1813-980-000	12	9	B2506-210-D00	18	22
BP-3000000-00	28	31	B1411-804-D00	12	45	B1814-210-DA0	12	5	B2507-210-D00	18	4
BP-6000000-00	28	32	B1411-804-000	6	45	B1814-210-D00	12	6	B2508-210-DA0	18	5
BT-0400251-EB	24	33	B1414-232-000	6	53	B1815-210-000	12	48	B2509-210-D00	18	23
BT-0600401-EB	26	16	B1501-127-000	10	31	B1815-980-000	12	47	B2509-210-D00	20	10
B1104-210-D00	2	4	B1501-210-DA0	8	2	B1817-210-DAA	12	3	B2509-704-000	20	14
B1105-210-D00	2	5	B1502-210-D00	8	7	B1817-210-DAB	12	4	B2510-210-D00	20	13
B1106-210-D00	4	1	B1503-210-DA0	8	3	B1817-210-DAC	40	3	B2511-210-D00	20	5
B1107-210-D00	2	1	B1504-210-D00	8	4	B1817-210-DAD	40	4	B2512-210-D00	18	18
B1108-210-D00	4	5	B1505-210-D00	8	5	B1818-210-DOA	12	21	B2513-210-D00	18	16
B1109-210-DA0	4	3	B1506-210-D00	8	6	B1818-210-DOB	12	22	B2513-210-D00	20	2
B1110-210-DA0	4	6	B1507-210-D00	8	1	B1819-280-000	12	49	B2514-210-D00	18	17
B1111-210-D00	2	2	B1508-210-D00	8	9	B1820-210-D00	12	7	B2514-210-D00	20	3
B1111-232-000	2	38	B1509-210-D00	8	10	B1820-215-PA0-A	12	16	B2518-210-D00	20	6
B1112-210-D00	4	2	B1510-210-D00	8	15	B1821-210-D00	12	8	B2519-210-D00	18	6
B1113-210-D00	4	8	B1511-210-D00	8	16	B1822-215-P00	12	17	B2520-210-DOA	18	7
B1113-223-C00	4	9	B1513-210-D00	8	21	B1828-210-DAA	12	24	B2520-210-DOB	18	8
B1115-210-D00	2	3	B1515-210-D00	8	12	B1828-210-DOA	12	25	B2521-210-D00	18	9
B1115-232-0A0	16	3	B1515-210-D00	8	23	B1836-210-D00	12	1	B2522-210-D00	18	10
B1115-232-000	16	6	B1516-210-D00	8	13	B1901-210-DA0	6	41	B2523-210-D00	20	11
B1116-210-D00	2	9	B1519-026-00G	18	43	B1901-210-DC0	6	40	B2524-210-D00	20	12
B1116-804-000	16	47	B1520-210-D00	8	11	B1903-210-000	6	43	B2525-205-000	20	16
B1117-210-D00	2	7	B1522-210-D00	8	14	B1903-552-000	6	46	B2525-210-D00	20	8
B1118-210-DA0	4	7	B1525-210-D00	8	8	B1904-280-000	6	48	B2526-210-D00	18	21
B1121-210-D00	2	6	B1526-804-000	8	50	B1905-541-000	6	44	B2527-210-000	18	11
B1122-210-D00	2	8	B1529-890-00C-A	2	18	B2102-816-000-A	10	36	B2528-210-D00	20	4
B1123-210-D00	2	10	B1530-210-D00	8	17	B2107-210-DA0	13	1	B2529-210-D00	18	15
B1123-210-000	4	10	B1601-210-DOB	40	1	B2107-210-D00	13	2	B2529-210-D00	20	1
B1123-280-000	2	39	B1601-210-DOC	40	2	B2110-210-D00	13	33	B2530-210-D00	18	42
B1124-210-000	4	11	B1601-210-D00	10	1	B2111-210-D00	13	3	B2534-210-D00	18	20
B1125-210-D00	2	11	B1603-210-D00	10	3	B2301-210-D00	16	1	B2536-210-D00	20	9
B1125-215-P00	2	40	B1604-210-D00	10	2	B2302-205-0AA	14	9	B2548-210-D00	20	7
B1126-552-000	2	41	B1606-210-D00	10	8	B2302-280-0A0	14	8	B2550-210-D00	20	1
B1129-210-000	2	42	B1607-210-D00	10	9	B2302-280-000	14	13	B2550-210-D00	24	1
B1131-528-000	38	14	B1609-210-D00	10	5	B2303-205-000	16	46	B2551-210-DA0	22	16
B1143-210-000	2	93	B1610-210-D00	10	7	B2303-280-000	14	23	B2552-210-D00	22	11
B1144-210-000	6	19	B1611-210-D00	10	17	B2304-210-D00	14	1	B2552-210-D00	22	4
B1148-555-000	2	21	B1611-210-00A	10	32	B2305-205-000	14	11	B2553-210-DOA	40	5
B1178-191-000	2	43	B1611-804-000-A	10	33	B2306-210-D00	14	3	B2553-210-DOB	40	6
B1181-210-D00	4	4	B1612-210-D00	10	6	B2308-210-D00	14	2	B2553-210-D00	22	10
B1201-210-D00	6	7	B1615-210-D00	10	37	B2312-210-D00	16	15	B2554-210-DOA	40	7
B1202-210-000	6	66	B1620-210-D00	10	10	B2313-280-000	14	12	B2554-210-DOB	40	8
B1203-210-D00	6	10	B1621-210-D00	10	11	B2315-210-D00	14	4	B2554-210-DOC	40	9
B1203-210-000	6	18	B1622-210-D00	10	12	B2401-210-D00	16	14	B2554-210-D00	24	6
B1206-210-D00	6	9	B1626-210-D00	10	41	B2402-210-D00	16	10	B2556-210-DOA	40	10
B1207-210-D00	6	6	B1626-220-000	22	35	B2404-210-DA0	16	19	B2556-210-DOB	40	11
B1208-210-D00	6	8	B1626-220-000	24	30	B2407-210-D00	16	17	B2557-210-DA0	38	19
B1208-980-00A	6	20	B1626-555-000	22	33	B2408-210-D00	16	13	B2557-280-00C	22	31
B1208-980-00B	6	21	B1627-210-D00	10	16	B2409-210-D00	16	11	B2560-210-D00	24	3
B1208-980-00C	6	22	B1628-210-D00	8	18	B2411-210-000	16	43	B2560-372-000	40	14
B1208-980-00D	6	23	B1628-210-D00	10	20	B2412-210-D00	16	12	B2561-210-D00	24	12
B1212-210-D00	6	13	B1629-210-D00	10	19	B2413-210-D00	16	18	B2562-210-D00	24	13
B1213-210-D00	6	1	B1629-224-000	10	34	B2414-280-0A0	16	31	B2564-210-D00	24	2
B1214-210-D00	6	2	B1630-210-D00	10	4	B2415-280-0A0	16	29	B2564-215-000	38	17
B1215-210-D00	6	11	B1631-210-D00	10	18	B2416-210-0A0	16	30	B2566-210-D00	24	10
B1216-210-D00	6	12	B1632-210-D00	10	15	B2416-280-000	16	28	B2567-210-D00	24	11
B1223-771-000	6	56	B1633-210-D00	10	13	B2417-210-000	16	33	B2570-210-D00	22	2
B1230-210-D00	6	5	B1634-210-D00	10	71	B2417-280-000	16	42	B2571-210-D00	22	3
B1231-210-D00	6	3	B1641-562-000	10	29	B2418-280-000	16	27	B2572-210-D00	22	12
B1232-210-D00	6	4	B1642-210-D00	10	14	B2421-210-AA0	16	26	B2572-210-D00	24	5
B1401-210-A00	6	49	B1643-470-000	6	24	B2423-280-00A	16	37	B2572-229-000	40	19
B1402-280-000	6	50	B1649-161-000	10	35	B2423-280-00B	16	38	B2573-210-D00	22	9
B1403-280-000	6	54	B1649-161-000	14	25	B2423-280-00C	16	39	B2574-210-D00	22	6
B1404-280-000	6	47	B1649-161-000	16	45	B2423-280-00D	16	40	B2575-210-D00	22	7
B1405-210-000	6	51	B1701-210-D00	8	46	B2424-210-000	16	25	B2576-210-D00	22	17
B1406-210-000	6	52	B1701-210-000	8	19	B2425-210-DAA	16	20	B2577-210-D00	22	4
B1407-210-D00	6	42	B1702-210-D00	8	47	B2425-210-DAB	16	21	B2578-210-D00	22	5
B1408-180-000	10	30	B1703-210-D00	8	48	B2425-210-000	16	22	B2579-210-D00	22	8
B1411-552-0A0	6	55	B1802-210-D00	12	32	B2426-210-00A	16	23	B2580-210-D00	22	18
B1411-804-A00	12	38	B1805-210-D00	12	2	B2426-210-00B	16	24	B2581-210-D00	22	14
B1411-804-A00	12	42	B1806-210-D00	12	23	B2431-215-000	16	48	B2582-210-D00	22	15
B1411-804-B00	12	39	B1806-210-D00	38	18	B2440-210-D00	16	16	B2583-210-D00	22	13
B1411-804-B00	12	43	B1808-210-D00	12	26	B2501-210-DA0	18	1	B2587-210-000	40	20
			B1808-980-000	12	46	B2501-210-D00	18	2	B2589-210-D00	40	16

NUMERICAL INDEX OF PARTS

索引

PART NO 品番	PAGE 頁	REF NO	PART NO 品番	PAGE 頁	REF NO	PART NO 品番	PAGE 頁	REF NO	PART NO 品番	PAGE 頁	REF NO
B2590-210-DAO	24	7	B8267-180-000	2	47	HA-0042600-00	37	12	M8601-580-AAO	36	18
B2591-210-DAO	24	8	B8404-352-000	10	38	HD-0005700-0A	6	68	M8602-580-OAO	34	3
B2592-210-000	38	9	B9101-552-000	38	1	HD-0005700-0A	18	46	M8602-580-OAO	36	35
B2593-210-DAO	40	12	B9109-555-000	38	2	HD-0013500-00	20	35	M8603-580-OAO	34	4
B2593-210-D00	40	13	B9110-012-000	38	3	HF-0041050-PO	37	29	M8603-580-OAO	36	36
B2594-210-D00	40	15	B9111-012-000	38	4	HK-0266500-80	34	26	M8604-580-AAO	34	8
B2598-210-D00	40	17	B9113-012-000	38	5	HK-0346100-2D	8	45	M8604-580-AAO	36	20
B2599-210-D00	40	18	B9121-012-000	30	31	HK-0346100-2E	10	39	M8604-580-OAO	34	7
B2610-210-D00	22	19	B9121-220-OAO	38	11	HK-0346100-20	13	17	M8604-580-OAO	36	19
B2610-210-D00	24	9	B9140-372-000	38	6	HK-0346100-40	26	11	M8605-580-OAO	34	9
B2617-771-000	16	53				HK-0346101-00	37	6	M8605-580-OAO	36	21
B2619-372-000	14	24	CM-2001000-01	34	24	HK-0346101-00	37	16	M8606-580-OAO	32	3
B2646-215-000	40	21	CM-3001000-01	34	25	HK-0346200-20	16	52	M8606-580-OAO	36	38
B2702-210-000	14	40	CM-3001001-01	34	54	HK-0346300-00	16	51	M8610-580-OAO	34	2
B2703-210-000	2	82	CM-3002000-B2	2	91	HK-0346400-00	13	18	M8901-580-AAO	34	20
B2707-761-000	2	44	CM-3002000-02	2	92	HK-0346400-00	26	14	M8901-580-AAO	36	22
B3107-804-000	14	15	CM-3002003-A1	2	90	HK-0346400-00	37	7	M8901-580-BAO	34	21
B3111-352-000	16	8	CM-3002003-01	2	89	HK-0346400-00	37	17	M8901-580-BAO	36	23
B3112-761-000	14	14	CM-5001000-01	30	41	HK-0542500-40	34	27	M8902-580-000	37	21
B3114-232-000	14	19	CQ-2020000-00	28	18	HM-0008600-10	34	28	M9001-580-OAO	36	24
B3114-771-000	2	45	CQ-2522000-00	12	14	HW-2003900-00	13	20	M9002-580-OAO	36	25
B3119-771-000	14	16	CQ-2522000-00	28	19	HW-5000700-00	13	21	M9003-580-OAO	36	3
B3120-125-000	14	17	CS-0700811-SH	10	73	HX-0005600-0B	34	29	M9004-580-OAO	36	4
B3123-352-000	16	4	CS-079073A-SH	10	42	HX-0012300-0A	2	83	M9005-580-OAO	36	26
B3125-012-000	16	7	CS-079073A-SH	22	36	HX-0014700-0C	34	30	M9007-580-OAO	36	27
B3126-012-000	14	18	CS-079073A-SH	24	34	HX-0015000-0J	2	79	M9008-580-OAO	36	28
B3126-012-000	16	5	CS-080081C-SH	12	52	HX-0022300-0A	8	54	M9009-580-OAO	36	29
B3132-552-000	14	20	CS-080081C-SH	16	44	HX-0030700-00	34	68	M9010-580-OAO	36	30
B3204-210-DAO	2	13	CS-080081C-SH	16	54	HX-0033900-0D	34	31	M9012-580-OAO	32	6
B3204-210-DB0	2	12	CS-1000811-SP	12	50	HX-0035400-00	34	5	M9012-580-OAO	36	39
B3205-210-000	2	19	CS-147121E-SH	6	27	HX-0040700-00	34	32	M9014-580-OAO	36	5
B3212-761-000	2	23	CS-1701011-SZ	8	24	HX-0041000-00	34	33	M9015-580-OAO	36	6
B3213-205-000	6	38							M9016-580-OAO	36	7
B3214-047-000	2	35	D1232-555-B00	6	26	MAO-11108N00	30	34	M9017-580-OAO	36	8
B3501-210-000	2	46	D1510-491-D00	10	40	MC-2005010-00	6	64	M9018-580-OAO	36	11
B3502-220-OAO	28	9	D2112-555-B00	28	17	MC-2005010-02	38	22	M9019-580-OAO	36	12
B3504-280-000	12	11	D2431-555-B00	14	26	MC-3720011-00	6	65	M9020-580-AAO	36	32
B3505-210-D00	28	1	D2468-555-B00	8	22	MC-3720011-02	38	23	M9020-580-OAO	36	31
B3505-280-000	12	10	D2502-232-D00	22	34	MDP-170B1800	6	63	M9021-580-OAO	36	13
B3506-210-D00	28	2	D2502-232-D00	24	31	MDP-170B1802	38	21	M9022-580-OAO	36	33
B3507-220-000	28	11	D2587-L8W-B00	16	49	MDP-500B1400	6	62	M9023-580-OAO	36	37
B3507-280-000	28	16	D2588-L8W-B00	16	50	MDP-500B1402	38	20	M9024-580-OAO	36	9
B3508-220-000	28	8	D2611-555-B00-A	28	33	M1001-580-000	34	10	M9025-580-OAO	36	14
B3508-280-000	28	12	D3112-L4B-B00	14	10	M1002-580-OAO	34	11	M9026-580-OAO	36	15
B3508-280-000	28	13	D3310-555-D00	8	20	M1003-580-000	34	12	M9027-580-OAO	36	34
B3508-280-000	28	14	D8113-555-B00	30	17	M1005-580-000	34	13	M9028-580-OAO	36	10
B3509-210-D00	28	3	D8204-555-D00	30	30	M1006-580-000	34	14	M9029-580-OAO	34	67
B3509-280-000	28	15				M1011-580-000	32	10	M9640-510-00A	34	56
B3518-210-000	28	4	EA-9500B01-00	26	12	M1012-580-000	37	3			
B3518-210-000	28	7	EA-9500B01-00	37	5	M1014-580-000	34	15	NM-3034000-SF	34	34
B3520-220-000	28	5	EA-9500B01-00	37	15	M1016-580-000	37	13	NM-6030003-SC	34	35
B3522-210-OAO	28	6	EA-9500B02-00	34	69	M1017-580-000	32	14	NM-6040003-SC	16	55
B3523-220-000	28	10	EA-9502B05-00	37	8	M1030-580-000	32	7	NM-6050001-SD	8	51
B3523-220-000	28	34	EA-9502B05-00	37	18	M1031-580-OAO	32	8	NM-6050001-SE	31	13
B3549-850-000	13	35	EA-9502B05-00	37	28	M1031-580-000	32	9	NM-6050001-SE	31	17
B4001-210-D00	6	67	E8523-304-000	37	28	M1032-580-000	32	11	NM-6050001-SP	16	56
B4004-210-D00	18	45	E9567-319-000	34	23	M2001-580-000	34	16	NM-6050001-SP	18	26
B4007-210-D00	18	24	E9613-601-000	37	26	M2001-580-000	34	73	NM-6060001-SC	2	48
B4008-210-D00	20	34	E9629-252-000	37	27	M3002-580-00B	34	18	NM-6060001-SC	30	35
B4110-210-D00	2	80				M3003-580-000	37	25	NM-6060001-SC	34	65
B4130-210-DAO	2	81	GAF-01007000	6	25	M3004-511-00A	37	24	NM-6080001-SC	30	36
B4715-215-OAO	26	4	GPF-06060000	30	18	M3005-511-00A	34	17	NM-6080721-SE	26	20
B8101-210-AAB	30	8	GPF-06070000	30	19	M3005-580-00A	32	4	NM-6080721-SE	30	20
B8101-210-DAA	30	2	GPF-06080000	30	14	M3005-580-00B	32	5	NM-6120003-SE	30	11
B8101-210-DAO	30	1	GPK-26002000	37	10	M8510-580-AAO	32	1	NM-6160511-SE	31	18
B8105-210-AAA	30	9	GPK-26002000	37	20	M8510-580-BAO	32	2	NS-6090310-SP	2	49
B8110-210-D00	30	24	G5126-172-000	24	32	M8520-580-OAO	36	1	NS-6090310-SP	2	50
B8131-019-000	38	8	G5430-116-000	26	7	M8520-580-OAO	37	1	NS-6090310-SP	13	23
B8133-019-000	38	7	G6705-152-UOA	34	55	M8521-580-OAO	36	2	NS-6110310-SP	2	37
B8150-210-000	30	10	G8124-270-000	26	5	M8521-580-OAO	37	11	NS-6110310-SP	10	43
B8153-771-000	30	16				M8540-580-AAO	34	70	NS-6110310-SP	13	24
B8201-210-D00	30	23	HA-0005900-00	13	19	M8540-580-OAO	34	19	NS-6110310-SP	14	27
B8202-205-000	30	27	HA-0030300-0A	34	59	M8541-580-OAO	32	13	NS-6110310-SP	16	57
B8203-205-000-A	30	28	HA-0030300-0A	36	17	M8599-580-AAO	37	23	NS-6110420-SP	16	58
B8210-012-000	30	29	HA-0042500-00	34	58	M8599-580-OAO	37	22	NS-6120310-SP	14	41
B8211-206-000	26	15	HA-0042500-00	36	16	M8601-580-AAO	34	1	NS-6120630-SP	16	59
			HA-0042600-00	37	2						

N U M E R I C A L I N D E X O F P A R T S

索引

PART NO 品番	PAGE 頁	REF NO	PART NO 品番	PAGE 頁	REF NO	PART NO 品番	PAGE 頁	REF NO	PART NO 品番	PAGE 頁	REF NO
NS-6150310-SP	2	51	SL-4030681-SF	34	66	SS-1060210-TP	16	32	SS-7110840-SP	12	28
NS-6150310-SP	16	9	SL-4030681-SF	34	72	SS-1110640-TP	10	53	SS-7110840-SP	13	36
NS-6620310-SP	10	44	SL-4030881-SF	34	6	SS-1110640-TP	16	65	SS-7110840-SP	22	26
NS-6660430-SP	12	53	SL-4031081-SF	6	69	SS-1110840-SP	4	14	SS-7110840-SP	22	27
			SL-4031081-SF	18	47	SS-1110840-SP	4	15	SS-7110840-SP	24	23
PA-1602006-A0	24	35	SL-4032591-SC	34	71	SS-1110840-SP	4	17	SS-7110840-SP	28	25
PB-0000100-00	38	13	SL-4040881-SF	34	39	SS-3090610-SP	2	53	SS-7110910-SP	13	37
PC-0105070-00	26	2	SL-4040881-SF	34	41	SS-4090715-SP	2	54	SS-7111110-TP	12	30
PF-0552040-B0	26	8	SL-4040881-SF	37	9	SS-4110515-SP	2	56	SS-7111120-SP	10	58
PH-0500322-C0	8	25	SL-4040881-SF	37	19	SS-4110715-SP	2	84	SS-7111410-SP	6	34
PJ-0305200-01	26	9	SL-4040891-SC	34	40	SS-4110715-SP	4	16	SS-7111810-TP	20	28
PJ-0460525-03	24	36	SL-4041081-SF	34	42	SS-4110715-SP	28	27	SS-7151210-SP	8	37
PJ-3040651-01	26	3	SL-4041081-SF	34	43	SS-4110815-SP	2	58	SS-7151210-SP	10	61
PJ-3050652-02	26	10	SL-4041091-SC	34	46	SS-4110915-SP	2	57	SS-8090610-SP	14	21
PJ-3090052-03	26	6	SL-4041091-SC	34	47	SS-4111015-SP	2	55	SS-8110422-TP	2	24
PJ-3095200-01	38	12	SL-4041091-SC	34	48	SS-4111015-SP	2	59	SS-8110422-TP	2	66
PS-0150042-K0	4	12	SL-4041091-SC	34	61	SS-4111415-SP	22	25	SS-8110422-TP	10	74
PS-0400142-KH	6	16	SL-4041281-SF	34	49	SS-4111415-SP	24	21	SS-8110422-TP	13	28
PV-0351130-A0	26	1	SL-4042081-SC	26	21	SS-4120615-SP	28	21	SS-8110422-TP	20	29
PX-9500090-00	26	13	SL-4051081-SF	34	50	SS-4120615-SP	28	28	SS-8110510-SP	6	35
			SL-4051091-SC	26	17	SS-4120915-SP	4	18	SS-8110520-TP	12	51
RC-0470611-KP	10	45	SL-4061091-SC	6	29	SS-4120915-SP	6	70	SS-8111610-SP	6	39
RC-0560711-KP	2	27	SL-9061293-SE	30	15	SS-4120915-SP	16	66	SS-8120740-SP	8	38
RC-3000002-KP	6	28	SL-9082093-SE	26	18	SS-4120915-SP	16	67	SS-8120740-SP	8	39
RE-0250000-K0	13	25	SL-9082093-SE	30	12	SS-4120915-SP	28	20	SS-8120740-SP	10	59
RE-0300000-K0	12	18	SL-9082093-SE	30	21	SS-4121015-SP	2	60	SS-8120740-SP	14	35
RE-0300000-K0	22	37	SM-0040601-SC	34	51	SS-4121015-SP	2	61	SS-8150822-TP	6	36
RE-0300000-K0	22	38	SM-0040601-SC	34	52	SS-4150915-SP	2	62	SS-8150822-TP	12	29
RE-0300000-K0	24	37	SM-0051001-SC	20	21	SS-4150915-SP	2	63	SS-8150822-TP	16	68
RE-0500000-K0	2	17	SM-1033501-SC	34	53	SS-6060410-TP	12	56	SS-8151550-SP	6	57
RE-0500000-K0	10	46	SM-1040801-SC	4	13	SS-6090440-SP	12	12	SS-8660610-TP	6	61
RE-0500000-K0	13	26	SM-1040801-SP	22	20	SS-6090620-SP	2	64	SS-8660610-TP	10	63
RE-0500000-K0	24	38	SM-1040801-SP	24	14	SS-6090620-TP	13	27	SS-8660610-TP	10	64
RE-0600000-K0	18	27	SM-3065052-TC	34	62	SS-6090670-TP	6	58	SS-8661012-TP	16	69
RE-0600000-K0	20	17	SM-4030601-SN	13	30	SS-6092120-SP	28	22	SS-9110920-CP	14	36
RE-0700000-K0	22	39	SM-4030601-SN	13	31	SS-6092120-SP	28	23	SS-9120910-TP	8	40
RE-0900000-K0	12	54	SM-4031851-SR	34	44	SS-6092120-SP	28	26	SS-9150910-SP	20	30
RO-0922702-00	2	26	SM-4050855-SP	4	20	SS-6110430-TP	16	35	SS-9661230-CP	6	60
			SM-4051405-SE	31	12	SS-6110610-TP	4	19	ST-4031051-SN	32	12
SB-1070001-00	10	70	SM-6040602-TP	16	63	SS-6110610-TP	10	54	ST-5041051-SN	37	4
SB-1080005-00	8	26	SM-6040602-TP	18	30	SS-6110610-TP	18	14	ST-5041051-SN	37	14
SB-1080005-00	18	28	SM-6040602-TP	18	31	SS-6111010-SP	18	37	S9622-710-000	34	36
SB-1080005-00	20	18	SM-6040602-TP	20	36	SS-6111010-SP	18	44			
SB-4080001-00	18	29	SM-6040802-TP	18	12	SS-6111140-SP	2	68	TA-0750704-R0	2	69
SB-4080001-00	20	19	SM-6041002-TP	18	13	SS-6111140-SP	28	24	TA-1050504-R0	2	70
SB-7100002-00	22	40	SM-6041002-TP	24	15	SS-6111620-SP	18	38	TA-1050504-R0	2	88
SB-7100002-00	24	39	SM-6041202-TP	18	32	SS-6120940-SP	10	62	TA-1250406-R0	2	71
SB-7160002-00	8	27	SM-6041202-TP	22	21	SS-6120940-SP	14	32	TA-1680605-R0	2	72
SD-0400191-TP	10	47	SM-6041202-TP	24	16	SS-6121210-SP	6	31	TA-2100904-R0	2	73
SD-0500803-TP	16	60	SM-6041402-TP	16	64	SS-6121212-TP	12	57			
SD-0530221-SP	14	28	SM-6041802-TP	20	20	SS-6151220-SP	10	55	WP-0320501-SC	13	32
SD-0600402-TP	10	49	SM-6051002-TP	24	17	SS-6151220-SP	10	60	WP-0430800-SC	10	72
SD-0640321-SP	10	48	SM-6051202-TP	8	34	SS-6151220-SP	12	58	WP-0430801-SC	20	31
SD-0640391-TP	14	30	SM-6053502-TP	18	33	SS-6151412-TP	6	32	WP-0450000-SD	2	74
SD-0640482-SP	14	31	SM-6060802-TP	8	44	SS-6151812-TP	14	33	WP-0450000-SD	2	75
SD-0650305-TP	16	61	SM-6061002-TP	22	22	SS-6681712-TP	6	33	WP-0450000-SD	6	37
SD-0650321-TP	13	29	SM-6061002-TP	24	18	SS-7080510-TP	6	59	WP-0450000-SD	10	67
SD-0720321-TP	14	29	SM-6061202-TP	20	22	SS-7090410-SP	16	36	WP-0450000-SD	24	24
SD-0720331-SP	8	30	SM-6061402-TN	22	23	SS-7090620-TP	14	34	WP-0450000-SD	28	30
SD-0790402-TP	10	52	SM-6061402-TN	24	19	SS-7090850-SP	2	85	WP-0450801-SD	4	21
SD-0790501-SP	8	32	SM-6061610-SC	31	6	SS-7090910-SP	10	56	WP-0450801-SD	13	38
SD-0790601-SP	8	29	SM-8040502-TP	18	34	SS-7090910-SP	38	16	WP-0450846-SP	16	41
SD-0800341-SP	8	28	SM-8040502-TP	20	23	SS-7091110-SP	10	57	WP-0450846-SP	16	70
SD-0800341-SP	8	31	SM-8040602-TP	10	66	SS-7091110-SP	20	27	WP-0450846-SP	18	39
SD-0800341-SP	10	50	SM-8050802-TP	22	24	SS-7091410-SP	20	37	WP-0450846-SP	20	32
SD-0800402-TP	10	51	SM-8050812-TP	24	20	SS-7110340-SP	38	10	WP-0480856-SP	22	28
SD-0800422-CP	8	33	SM-8060602-TP	10	65	SS-7110510-SP	12	27	WP-0480856-SP	24	25
SD-0801021-TP	12	55	SM-8060602-TP	18	36	SS-7110710-SP	2	86	WP-0482086-SD	13	39
SD-1100301-TP	16	62	SM-8060602-TP	20	25	SS-7110710-SP	18	48	WP-0482086-SD	14	37
SK-3311600-SC	30	32	SM-8060612-TP	6	30	SS-7110710-SP	24	22	WP-0501016-SD	2	76
SK-3311600-SC	30	33	SM-8060612-TP	8	35	SS-7110710-SP	28	29	WP-0501016-SD	16	71
SK-3382001-SE	34	57	SM-8060802-TP	18	35	SS-7110720-SP	20	26	WP-0520656-SA	4	23
SK-3451600-SC	32	15	SM-8060802-TP	20	24	SS-7110740-TP	16	34	WP-0531000-SD	4	22
SK-3512001-SF	34	60	SM-8061612-TP	6	71	SS-7110840-SP	2	65	WP-0531001-SC	8	41
SL-4030681-SF	34	37	SM-9065513-SF	2	52	SS-7110840-SP	2	67	WP-0531001-SC	18	41
SL-4030681-SF	34	38	SM-9086523-SE	30	37	SS-7110840-SP	8	36	WP-0551016-SH	20	33

From the library of: Diamond Needle Corp

NUMERICAL INDEX OF PARTS

索引

PART NO 品番	PAGE 頁	REF NO	PART NO 品番	PAGE 頁	REF NO	PART NO 品番	PAGE 頁	REF NO	PART NO 品番	PAGE 頁	REF NO
WP-0611626-SP	10	68	135-18105	20	15						
WP-0611626-SP	10	69	135-51254	2	87						
WP-0621016-SD	2	77	137-16808	14	7						
WP-0621016-SD	2	78	137-16907	10	27						
WP-0621016-SH	8	43	137-17707	10	25						
WP-0641601-SC	8	52	137-22103	16	2						
WP-0641601-SC	30	38	137-22509	10	28						
WP-0651001-SC	22	29	138-16608	2	30						
WP-0651001-SC	22	30	138-16855	12	37						
WP-0651001-SC	24	26	138-17408	14	22						
WP-0651001-SC	24	27	170-07402	30	7						
WP-0651001-SC	34	63	177-00402	13	34						
WP-0651056-SD	14	38	178-45009	34	22						
WP-0740516-SP	10	75									
WP-0820526-SD	18	40	225-29457	2	36						
WP-0841600-SE	14	39	225-29465	2	32						
WP-0850002-SP	8	42	225-37658	2	14						
WP-0851846-SC	30	39	225-38151	2	20						
WP-0871602-SE	26	19	225-38300	2	25						
WP-0871602-SE	30	22	225-38409	2	15						
WP-0952616-SD	12	13	229-30309	31	14						
WP-1702600-SO	31	19	229-30358	31	1						
WP-2232916-SZ	8	53	229-30408	31	10						
WS-0310002-KR	13	22	229-30507	31	9						
WS-0310702-KS	34	45	229-30705	31	7						
WS-0410002-KP	20	38	229-30804	31	5						
WS-0410002-KP	22	32	229-30903	31	4						
WS-0410002-KP	24	28	229-31000	31	3						
WS-0410002-KP	24	29	229-31109	31	2						
WS-0510002-KN	31	16	229-31208	31	15						
WS-0610002-KN	30	40	229-31307	31	11						
WS-0610002-KN	34	64	229-31406	31	8						
100-04109	2	31									
101-02259	38	15									
105-02300	2	28									
105-23504	12	31									
106-18304	2	16									
110-06004	10	21									
110-10303	10	22									
110-47107	2	29									
110-71602	10	26									
110-71701	10	23									
110-72402	2	33									
110-72709	13	4									
110-93606	2	34									
111-10152	13	5									
111-10301	13	6									
111-10400	13	7									
111-10509	13	8									
111-10608	13	9									
111-10707	13	10									
111-10806	13	11									
111-10905	13	12									
111-11051	13	13									
111-11507	13	14									
111-11804	13	16									
111-12000	13	15									
111-55108	30	25									
111-55207	30	26									
111-58300	30	3									
111-58409	30	4									
111-58516	30	5									
111-58607	30	6									
111-59001	30	13									
112-17114	6	15									
112-17213	6	14									
113-92107	8	49									
118-47308	10	24									
135-08403	12	33									
135-08700	12	34									
135-08809	12	35									
135-08908	12	36									
135-13205	14	5									
135-13304	14	6									
135-18105	18	25									

From the library of: Diamond Needle Corp